



**monaco
distributors**

Ph: 1300 666 226

2/18 Ellemsea Cct
Lonsdale SA 5160 Australia

Phone: + 61 8 8326 0037
Fax: + 61 8 8326 6042

Email: contact@monacodistributors.com.au
Website: <http://www.monacodistributors.com.au/>

**POWERGRID
STANDARD RESIN SYSTEMS FOR STRUCTURAL SHAPES**

STANDARD POLYESTER (ISO) RESIN SYSTEM

The STANDARD POLYESTER RESIN SYSTEM refers to a NON FLAME RETARDANT isophthalic polyester resin system. This resin system is manufactured in olive green and incorporates ultraviolet inhibitors. Polyester resins exhibit good corrosion resistance, good electrical properties, low thermal conductivity and excellent mechanical properties.

FLAME RETARDANT (ISOFR) RESIN SYSTEM

This resin system exhibits the same characteristics as the Standard Polyester resin system PLUS a flame retardant rating of 25 or less when tested in accordance with ASTM E-84. The FLAME RETARDANT resin system is manufactured in grey and yellow. Other colour options available.

FLAME RETARDANT VINYL ESTER (VEFR) RESIN SYSTEM

This resin system is manufactured from vinyl ester resin which exhibits higher strength, improved strength and stiffness retention at elevated temperatures, and improved corrosion resistance. This system also meets a maximum flame spread rating of 25 and is produced in beige, grey and yellow.

TEMPERATURE EFFECTS

The approximate retention of mechanical properties at elevated temperatures are:

	TEMPERATURE	ISO/ISOFR	VEFR
Ultimate Stress	100°F	85%	90%
	125°F	70%	80%
	150°F	50%	80%
	175°F	not recommended	75%
	200°F	not recommended	50%
Modulus of Elasticity	100°F	100%	100%
	125°F	90%	95%
	150°F	85%	90%
	175°F	not recommended	88%
	200°F	not recommended	85%

The data in this corrosion guide is based on field service performance, laboratory testing and extrapolated values from our resin manufacturers' recommendations. Data shown is intended as a guide only. It is recommended that for a specific application, testing be done in the actual chemical environment.

The following conditions will effect the suitability of a specific resin laminate:

- Periodic changes in temperature
- Temperature spikes
- Changes in chemical concentrations
- Combinations of chemicals
- Exposure to vapors only
- Exposure to frequent splashes and spills
- Exposure to intermittent splashes and spills
- Frequency of maintenance wash down
- Load bearing or non-load bearing requirements

Chemical Environment	Maximum recommended Service Temperatures °F		Chemical Environment	Maximum recommended Service Temperatures °F	
	Vinylester	Polyester		Vinylester	Polyester
Acetic Acid, to 10%	170	80	Butyl Acetate	NR	NR
Acetic Acid, to 50%	180	NR	Butyl Alcohol	80	NR
Acetic Acid, Glacial	NR	NR	Calcium Carbonate	170	120
Acetone	NR	NR	Calcium Hydroxide	140	120
Aluminum Chloride	170	120	Calcium Hypochlorite	120	NR
Aluminum Hydroxide	140	120	Calcium Nitrate	170	120
Aluminum Nitrate	140	120	Calcium Sulfate	170	120
Aluminum Sulfate	170	120	Carbon Disulfate	NR	NR
Ammonium Chloride	170	120	Carbon Monoxide Gas	170	160
Ammonium Hydroxide, 5%	140	NR	Carbon Dioxide Gas	170	160
Ammonium Nitrate, to 50%	170	120	Carbon Tetrachloride, Liquid or Vapor	110	NR
Ammonium Nitrate, Saturated	170	NR	Chlorine, Dry Gas	170	NR
Ammonium Persulfate, to 25%	140	90	Chlorine, Wet Gas	170	NR
Ammonium Phosphate	170	120	Chlorine Water	140	NR
Ammonium Sulfate	170	120	Chloroform	NR	NR
Amyl Alcohol	80	NR	Chromic Acid, to 5%	110	NR
Barium Carbonate	170	120	Chromous Sulfate	140	120
Barium Chloride	170	120	Citric Acid	170	120
Barium Sulfate	170	120	Copper Chloride	170	170
Benzene	NR	NR	Copper Cyanide	170	170
Benzene Sulfonic Acid 50%	110	NR	Copper Nitrate	170	170
Benzoic Acid	170	120	Crude Oil, Sour	170	170
Benzyl Alcohol	NR	NR	Cyclohexane, Liquid and Vapour	170	NR
Borax	170	120	Diesel Fuel	140	90
Brine (Sodium Chloride Sol.)	170	120	Ethyl Acetate	NR	NR
Bromine, Liquid or Vapor	NR	NR	Phosphoric Acid, Vapour	170	120
Ethyl Alcohol	NR	NR	Potassium Aluminum Sulfate	170	120
Ethylene Glycol	170	120	Potassium Bicarbonate	110	100
Fatty Acids	170	80	Potassium Carbonate, to 10%	110	NR
Ferric Chloride	170	10	Potassium Chloride	170	120
Ferric Sulfate	170	110	Potassium Hydroxide	140	NR
Formaldehyde	110	NR	Potassium Nitrate	170	120
Fuel Oil	140	80	Potassium Sulfate	170	120
Gasoline, Aviation and Ethyl	140	80	Propylene Glycol	170	120
Glucose	170	100	Sodium Acetone	170	120
Glycerine	170	100	Sodium Benzoate	140	120
Hexane	120	90	Sodium Bicarbonate	140	120
Hydraulic Fluid (Glycol Based)	140	NR	Sodium Bisulfate	170	120
Hydraulic Fluid Skydraul	140	NR	Sodium Bisulfite	170	120
Hydrobromic Acid	110	NR	Sodium Borate	170	120
Hydrochloric Acid, up to 15%	140	80	Sodium Bromide	170	120
Hydrochloric Acid, Concentrated	110	NR	Sodium Carbonate, to 10%	140	70
Hydrogen Bromide, Dry Gas	140	80	Sodium Chloride	170	120
Hydrogen Bromine, Wet Gas	140	NR	Sodium Cyanide	170	120
Hydrogen Chloride, Dry Gas	170	80	Sodium Dichromate	170	120
Hydrogen Chloride, Wet Gas	170	80	Sodium Diphosphate	170	120
Hydrogen Fluoride, Sol or Vapor	140	NR	Sodium Hydroxide, 10%	140	NR
Hydrogen Peroxide, to 10%	110	NR			

Hydrogen Sulfate, Dry Gas	140	80	Sodium Hypochlorite, to 5!%	110	70
Hydrogen Sulfate, Wet Gas	140	80	Sodium Monophosphate	170	120
Isopropyl Alcohol	80	NR	Sodium Nitrate	170	120
JP-4	140	80	Sodium Nitrite	170	120
Kerosene	140	110	Sodium Sulfate	170	120
Lactic Acid	170	120	Sodium Tetraborate	140	120
Lead Acetate	170	120	Sodium Thiosulfate	140	120
Linseed Oil	170	100	Soy Oil	170	100
Lithium Chloride	170	120	Stearic Acid	170	120
Magnesium Carbonate	170	120	Styrene	NR	NR
Magnesium Chloride	170	120	Sulfamic Acid	170	120
Magnesium Hydroxide	170	100	Sulfated Detergents	NR	120
Magnesium Nitrate	170	120	Sulfite Liquor	160	100
Magnesium Sulfate	170	120	Sulfur Dioxide, gas-dry	170	120
Mercuric Chloride	170	120	Sulfur Dioxide, gas-wet	170	70
Mercury Metal	170	120	Sulfur Trioxide, gas-wet or dry	170	NR
Methyl Ethyl Ketone	NR	NR	Sulfuric Acid, to 25%	170	80
Mineral Oil	170	120	Tartaric Acid	170	120
Monochlorobenzene	NR	NR	Tetrachloroethylene	NR	NR
Naphtha	140	120	Toluene	NR	NR
Nickel Chloride	170	120	Trichloroethylene vapour	NR	NR
Nitric Acid, to 5%	110	100	Trisodium Phosphate	170	NR
Nitric Acid, Concentrated	NR	NR	Urea, 35%	110	NR
Nitric Acid, Vapour	140	100	Vinegar	170	150
Oleic Acid	170	120	Water, Distilled	180	150
Oxalic Acid	170	120	Water, Tap	180	120
Paper Mill Liquor	100	100	Zinc Chloride	170	120
Phenol Solution or Vapour	NR	NR	Zinc Nitrate	170	120
Phosphoric Acid	170	100	Zinc Sulfate	170	120
Phosphoric Acid, Salts thereof	170	120			

Typical Coupon Properties

The values listed below are test results from coupon tests performed in accordance with the designated ASTM Test.

LW= Lengthwise

CW=Crosswise

PF= Perpendicular to Laminate Face

<u>MECHANICAL PROPERTIES</u>	<u>ASTM</u>	<u>UNITS</u>	<u>VALUE</u>
Tensile Stress, LW	D-638	psi	30,000
Tensile Stress, CW	D-638	psi	7,000
Tensile Modulus, LW	D-638	10 ⁶ psi	2.5
Tensile Modulus, CW	D-638	10 ⁶ psi	0.8
Compressive Stress, LW	D-695	psi	30,000
Compressive Stress, CW	D-695	psi	15,000
Compressive Modulus, LW	D-695	10 ⁶ psi	2.5
Compressive Modulus, CW	D-695	10 ⁶ psi	1
Flexural Stress, LW	D-790	psi	30,000
Flexural Stress, CW	D-790	psi	10,000
Flexural Modulus, LW	D-790	10 ⁶ psi	1.8
Flexural Modulus, CW	D-790	10 ⁶ psi	0.8
Modulus of Elasticity, E	Full Section	10 ⁶ psi	2.8
Shear Modulus	-----	10 ⁶ psi	0.45
Short Beam Shear	D-2344	psi	4,500
Punch Shear	D-732	psi	10,000
Bearing Stress, LW	D-953	psi	30,000
Notched Izod Impact, LW	D-256	ft-Lbs/in	25
Notched Izod Impact, CW	D-256	ft-Lbs/in	4
<u>PHYSICAL PROPERTIES</u>	<u>ASTM</u>	<u>UNITS</u>	<u>VALUE</u>
Barcol Hardness	D-495	-----	45
24 Hour Water Absorption	D-570	% max	0.45
Density	D-792	lbs/in ³	.062 - .070
Coefficient of Thermal Expansion, LW	D-696	10 ⁻⁶ in/in/°C	8
<u>ELECTRICAL PROPERTIES</u>	<u>ASTM</u>	<u>UNITS</u>	<u>VALUE</u>
Arc Resistance, LW	D-495	seconds	120
Dielectric Strength, LW	D-149	kv/in	35
Dielectric Strength, PF	D-149	volts/mil	200
Dielectric Constant, PF	D-150	at 60hz	5

Polyester and Vinylester Fire Retardant Structural Profiles:

<u>FLAMMABILITY PROPERTIES</u>	<u>ASTM</u>	<u>UNITS</u>	<u>VALUE</u>
Tunnel Test	E-84	Flame Spread	25 max
Flammability	D-635	-----	Nonburning

Cross Sectional Tolerances

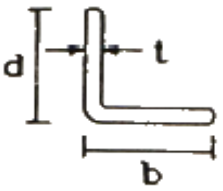
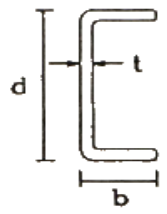
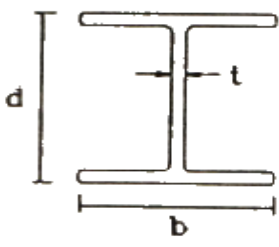
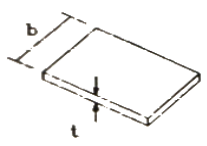
SHAPE	DIMENSION	TOLERANCES	MAXIMUM OR MINIMUM TOLERANCES
<p align="center">ANGLES</p> 	t = thickness	± 10%	± 0.010" minimum
	b= flange width	± 5%	± 0.094" maximum
	d= depth	± 5%	± 0.094" maximum
<p align="center">CHANNELS</p> 	t = thickness	± 10%	± 0.010" minimum
	b= flange width	± 5%	± 0.094" maximum
	d= depth	± 5%	± 0.094" maximum
<p align="center">BEAMS</p> 	t = thickness	± 10%	± 0.010" minimum
	b= flange width	± 5%	± 0.094" maximum
	d= depth	± 5%	± 0.094" maximum
<p align="center">FLAT SHEET</p> 	t = thickness	± 10%	± 0.040" maximum
	b= width	± 3%	± 0.094" maximum

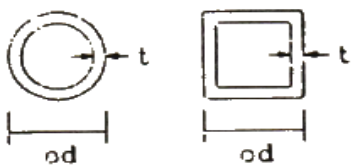

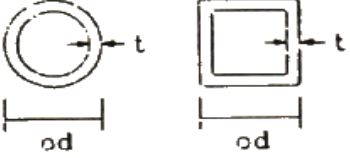
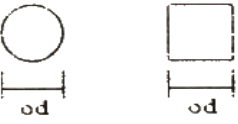

Cross Sectional Tolerances

SHAPE	DIMENSION	OUTSIDE DIMENSION CONDITION	TOLERANCES
ROUND & SQUARE TUBE 	t = thickness	Under 1"	± 20%
		1" and up	± 15%
	od= outside dimension	Under 2"	± 0.020"
		2" and up	± 0.040"
ROUND ROD & SQUARE BAR 	od= outside dimension	up to 3"	± 0.010"

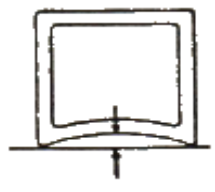
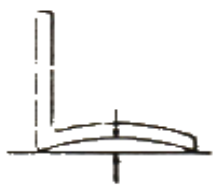



Flatness

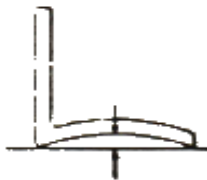
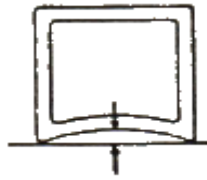

Flatness is measured in the centre with the weight of the profile minimizing the deviation by contact with a flat surface.

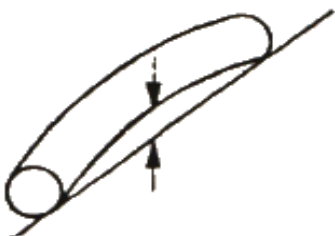
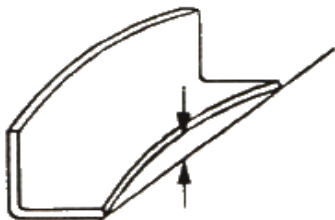
<p>STRUCTURAL SHAPES, RODS, BARS, & SHEET</p> 	Allowable deviation from flat		
	Width	All Thicknesses	
	Up to 1"	0.008"	
	Over 1"	0.008"/inch	
<p>HOLLOW SHAPES</p> 	Allowable deviation from flat		
	Width	Thicknesses 0.125" tp 0.188"	Thickness 0.189" and over
	Up to 1"	0.012"	0.008"
	Over 1"	0.012"/inch	0.008"/inch

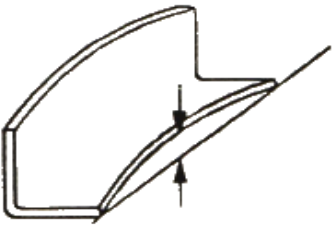
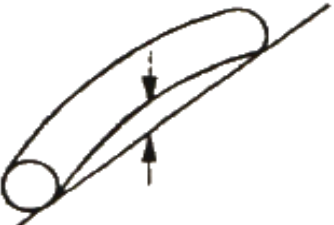

Straightness

Straightness is measured in the centre with the weight of the pultrusion minimizing the deviation by contact with a flat surface.

<p align="center">ANGLE, BEAM AND CHANNEL</p> 	Allowable deviation from straight	
<p align="center">RODS AND BARS</p> 	All widths	0.050"/foot
<p align="center">ROUND, SQUARE, AND RECTANGULAR TUBE</p> 	Allowable deviation from straight	
	Diameter/Depth	Per Foot
	Up to 1"	0.020"
	Over 1"	0.040"
	Allowable deviation from straight	
	Diameter/Depth	Per Foot
	Up to 2"	0.020"
	Over 2"	0.030"

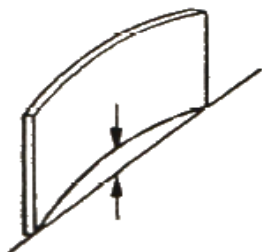

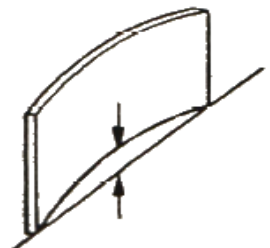

<p>SHEET AND PLATE</p> 	Allowable deviation from straight	
	All thicknesses and widths	0.025"/foot

Twist

Twist is measured with the weight of the pultrusion minimizing the twist

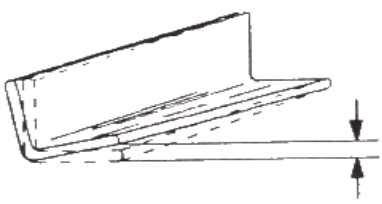
<p>ALL PROFILES</p> 	Allowable twist		
	Width/Depth	Per Foot	Per Piece Max
	Up to 1.499"	$\tan 1^\circ \times \text{width}$	$\tan 7^\circ \times \text{width}$
	1.500" to 2.999"	$\tan 1/2^\circ \times \text{width}$	$\tan 5^\circ \times \text{width}$
	3.000" and over	$\tan 1/3^\circ \times \text{width}$	$\tan 3^\circ \times \text{width}$

Angularity

ALL PROFILES	Allowable deviation from specific angle	
	thickness up to 3/4"	$\tan 1 1/2^\circ \times \text{width of flange in inches}$

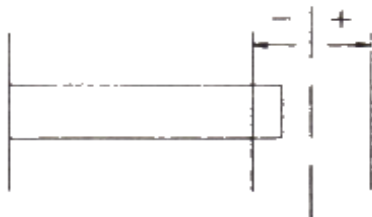

Cut Lengths

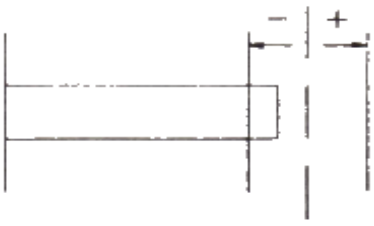
<p align="center">ALL PROFILES</p> 	Allowable deviation from specific angle	
	N/A	N/A

Squareness of Endcut

<p align="center">ALL PROFILES</p>	Allowable deviation from square	
	All thicknesses	tan 1° x width in inches

Section Properties

WF-BEAM

SECTION DIMENSIONS					SECTION PROPERTIES					
d	b	t	A	Wt	X - X			Y - Y		
in.	in.	in.	in. ²	lb./ft.	l	S	r	l	S	r
3	3	1/4	2.13	1.64	3.17	2.11	1.22	1.13	0.75	0.73
4	4	1/4	2.89	2.15	7.94	3.97	1.66	2.67	1.34	0.96
6	6	1/4	4.39	3.40	28.28	9.43	2.54	9.01	3.00	1.43
6	6	3/8	6.48	4.90	40.17	13.39	2.49	13.52	4.51	1.44
8	8	3/8	8.73	6.49	99.19	24.80	3.37	32.03	8.01	1.92
8	8	1/2	11.51	8.70	126.96	31.74	3.32	42.74	10.69	1.93
10	10	1/2	14.51	10.90	256.20	51.24	4.21	83.42	16.68	2.40
12	12	1/2	17.51	13.20	452.45	75.45	5.08	144.11	24.02	2.87

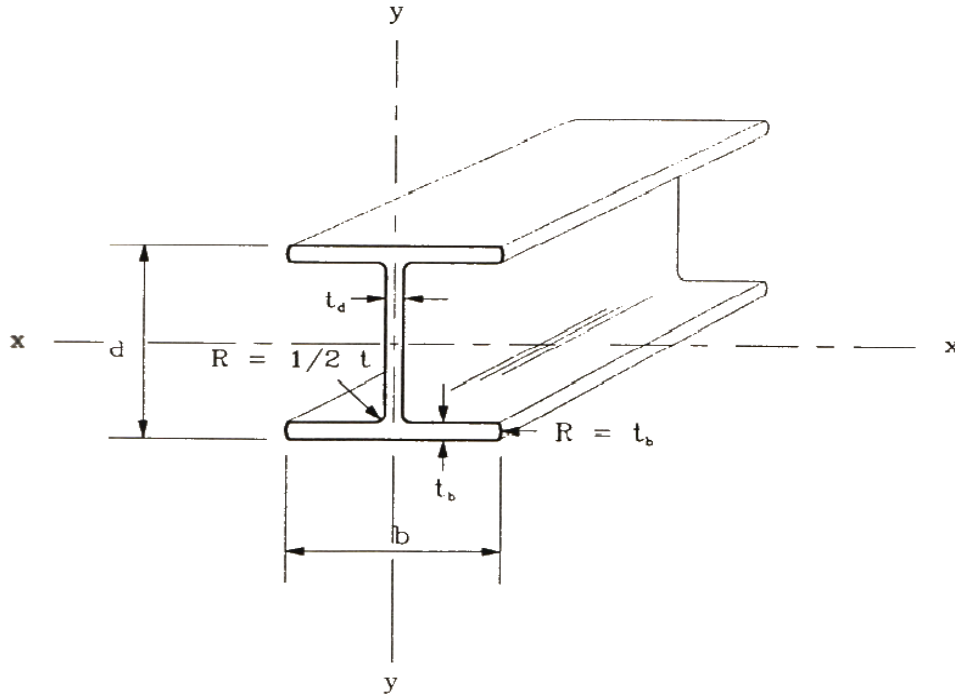

I-BEAM

SECTION DIMENSIONS					SECTION PROPERTIES					
d	b	t	A	Wt	X - X			Y - Y		
in.	in.	in.	in. ²	lb./ft.	l	S	r	l	S	r
3	1 1/2	1/4	1.38	1.10	1.75	1.17	1.13	0.14	0.19	0.32
4	2	1/4	1.88	1.50	4.41	2.21	1.53	0.34	0.34	0.43
6	3	1/4	2.88	2.20	16.99	5.66	2.43	1.13	0.75	0.63
6	3	3/8	4.23	3.20	22.35	7.45	2.30	1.71	1.14	0.64
8	4	3/8	5.73	4.30	55.55	13.89	3.11	4.03	2.02	0.84
8	4	1/2	7.51	5.70	70.62	17.66	3.07	5.40	2.70	0.85
10	5	3/8	7.22	5.78	111.63	22.33	3.93	7.85	3.14	1.04
10	5	1/2	9.51	7.20	143.29	28.66	3.88	10.51	4.21	1.05
12	6	1/2	11.51	8.70	253.96	42.33	4.70	18.11	6.04	1.26
18	4 1/2	3/8-1/2	10.92	8.70	498.15	55.35	6.75	7.66	3.40	0.84
24	7 1/2	3/8-3/4	19.90	15.20	1877.00	156.42	9.76	52.83	14.09	1.64

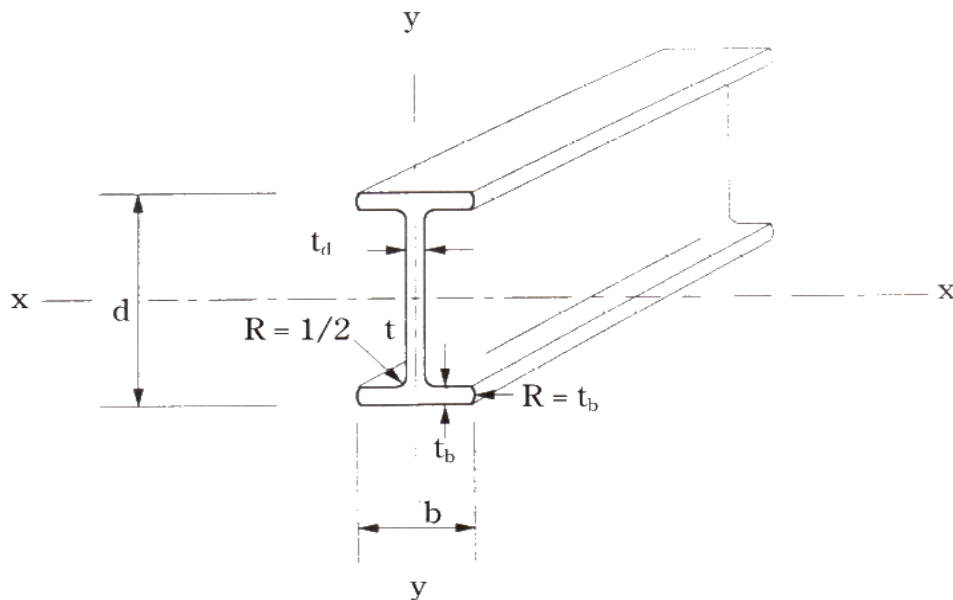

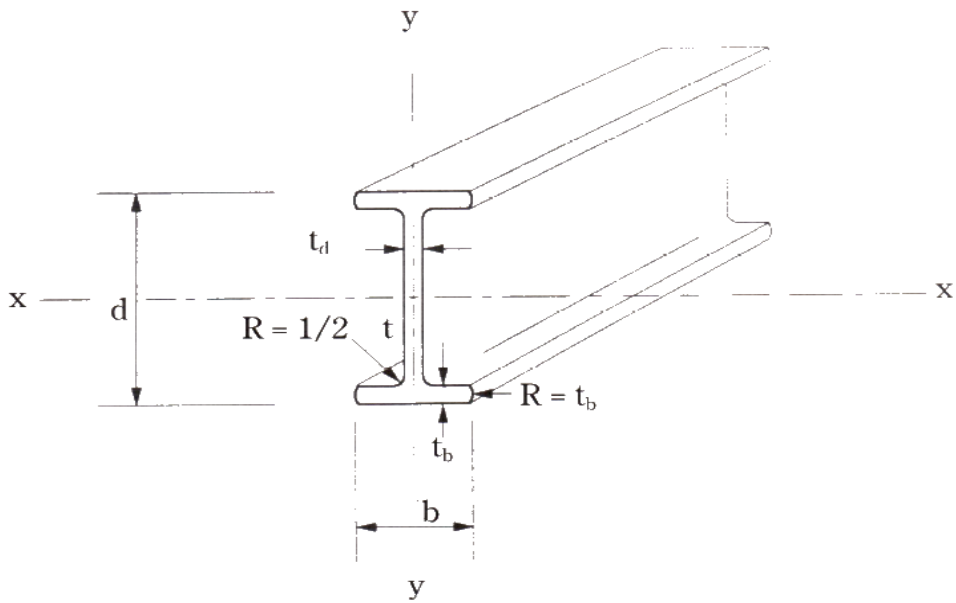

CHANNEL

SECTION DIMENSIONS								SECTION PROPERTIES					
d	b	t_d	t_b	A	Wt	R_i	R_o	X - X			Y - Y		
in.	in.	in.	in.	in. ²	lb./ft.	in.	in.	I	S	r	I	S	r
3	13/16	1/8	1/8	0.55	0.43	3/16	1/32	0.64	0.43	1.08	0.03	0.04	0.22
3	1	1/4	1/4	1.08	0.79	1/8	3/8	1.27	0.85	1.09	0.06	0.09	0.24
3	1 1/2	1/4	1/4	1.33	1.01	1/8	3/8	1.75	1.16	1.15	0.26	0.25	0.44
3 1/2	1 3/16	1/8	3/16	0.88	0.67	1/8	3/16	1.54	0.88	1.32	0.11	0.13	0.36
4	1 1/8	1/4	1/4	1.38	1.05	1/8	3/8	2.87	1.44	1.44	0.13	0.16	0.31
4	1 3/8	3/16	3/16	1.16	0.88	1/8	5/16	2.62	1.31	1.50	0.19	0.18	0.40
6	1 5/8	1/4	1/4	2.13	1.67	1/8	3/8	10.18	3.39	2.19	0.43	0.35	0.45
6	1 11/16	3/8	3/8	3.23	2.60	1/8	1/8	14.55	4.85	2.12	0.52	0.45	0.45
8	2 3/16	3/8	3/8	4.23	3.20	3/16	9/16	35.77	8.94	2.88	1.52	0.91	0.60
10	2 3/4	1/2	1/2	7.02	5.30	1/4	3/4	92.49	18.50	3.63	3.97	1.92	0.75

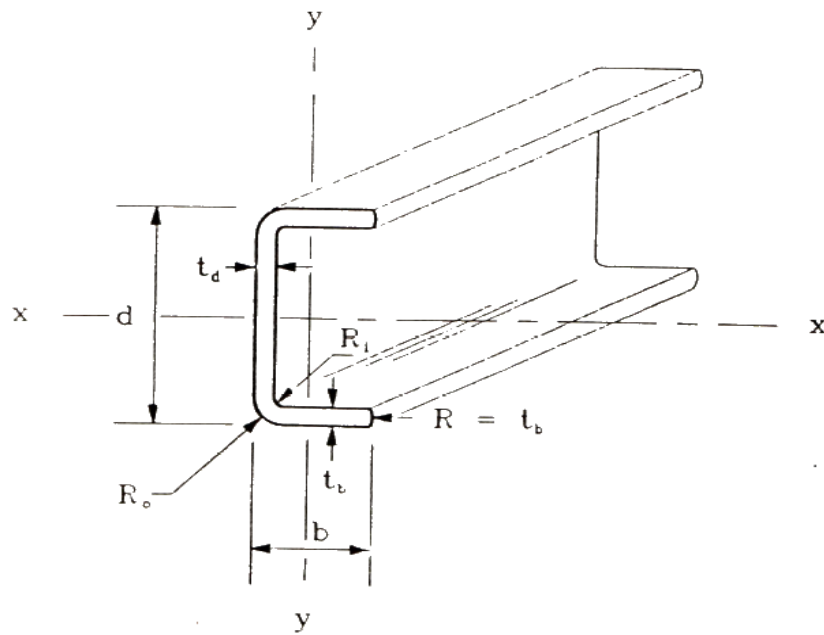

EQUAL LEG ANGLE

SECTIONAL DIMENSIONS				SECTIONAL PROPERTIES			
Depth	Wall	A	Wt	X - X / Y - Y			
h	t	in. ²	lb./ft.	I	S	r	x/y
in.	in.	in. ²	lb./ft.	in. ⁴	in. ³	in.	in.
1	0.13	0.23	0.18	0.02	0.05	0.31	0.29
1.25	0.13	0.29	0.22	0.04	0.05	0.38	0.36
1.5	0.19	0.52	0.40	0.11	0.10	0.46	0.44
1.5	0.25	0.67	0.54	0.14	0.13	0.45	0.47
2	0.25	0.92	0.70	0.33	0.23	0.59	0.59
3	0.25	1.42	1.08	1.24	0.58	0.93	0.84
3	0.38	2.09	1.61	1.76	0.83	0.91	0.89
3	0.50	2.70	2.11	2.22	1.07	0.91	0.93
4	0.25	1.92	1.45	3.04	1.04	1.26	1.09
4	0.38	2.84	2.18	4.35	1.52	1.24	1.14
4	0.50	3.70	2.89	5.56	1.97	1.23	1.18
6	0.50	5.70	4.45	19.91	4.60	1.87	1.68

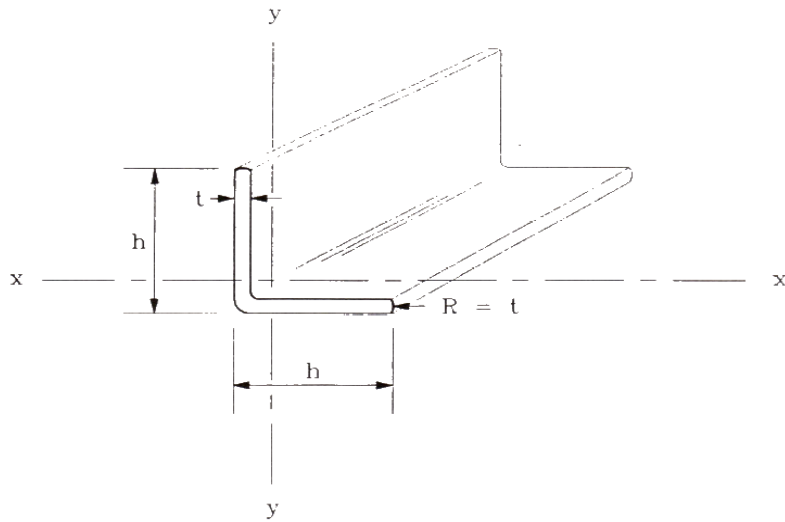

SQUARE TUBE

SECTION DIMENSIONS				SECTION PROPERTIES		
b	t	A	Wt	I	S	r
in.	in.	in. ²	lb./ft.	in. ⁴	in. ³	in.
1	1/8	0.43	0.32	0.06	0.11	0.36
1	1/4	0.74	0.55	0.08	0.16	0.33
1 1/4	1/8	0.56	0.41	0.12	0.19	0.46
1 1/4	1/4	0.99	0.75	0.18	0.28	0.42
1 1/2	1/8	0.68	0.50	0.22	0.29	0.56
1 1/2	1/4	1.24	0.98	0.34	0.45	0.52
1 3/4	1/8	0.81	0.61	0.36	0.41	0.67
1 3/4	1/4	1.49	1.13	0.58	0.66	0.62
2	1/8	0.93	0.70	0.55	0.55	0.77
2	1/4	1.74	1.32	0.91	0.91	0.73
2	3/8	2.44	1.85	1.13	1.13	0.68
2 1/4	1/8	1.06	0.81	0.80	0.71	0.87
2 1/4	1/4	1.99	1.51	1.35	1.20	0.83
3	1/8	1.43	1.08	1.98	1.32	1.18
3	1/4	2.74	2.07	3.50	2.33	1.13
4	1/4	3.74	2.83	8.82	4.41	1.53

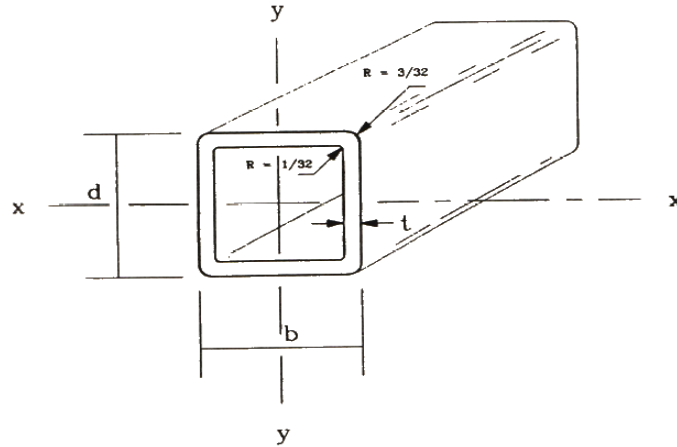

RECTANGULAR TUBE

SECTION DIMENSIONS						SECTION PROPERTIES					
d	b	t _h	t _w	A	Wt	X - X			Y - Y		
						I	S	r	I	S	r
in.	in.	in.	in.	in. ²	lb./ft.	in. ⁴	in. ³	in.	in. ⁴	in. ³	in.
1 1/2	3/4	1/8	1/8	0.50	0.39	0.13	0.17	0.51	0.04	0.11	0.32
1 1/2	1	1/8	1/8	0.56	0.44	0.16	0.21	0.53	0.08	0.16	0.40
2	1/2	1/8	1/8	0.56	0.44	0.22	0.89	0.63	0.02	0.07	0.18
2	1	1/8	1/8	0.69	0.54	0.33	0.33	0.69	0.11	0.21	0.39
4	1	1/8	1/8	1.19	0.90	2.04	1.02	1.31	0.20	0.40	0.42
4 3/8	1 3/8	1/8	3/16	1.52	1.18	3.60	1.64	1.54	0.47	0.69	0.79
4 1/2	1 3/4	1/8	3/16	1.69	1.29	4.52	2.07	1.64	0.85	0.97	0.71
5	2	1/8	1/8	1.69	1.32	5.20	2.08	1.76	1.12	1.12	0.85

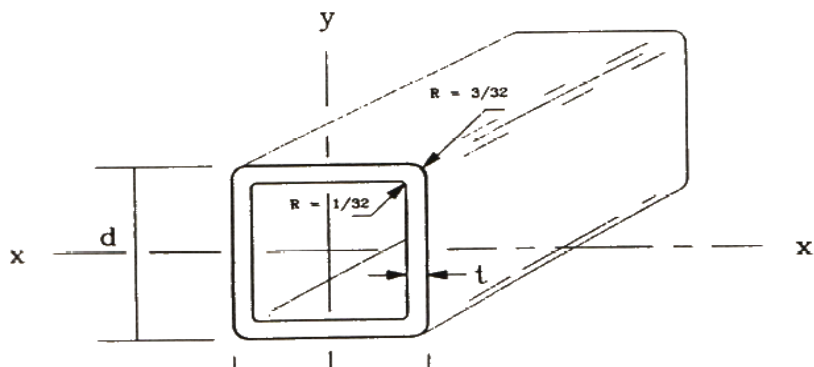

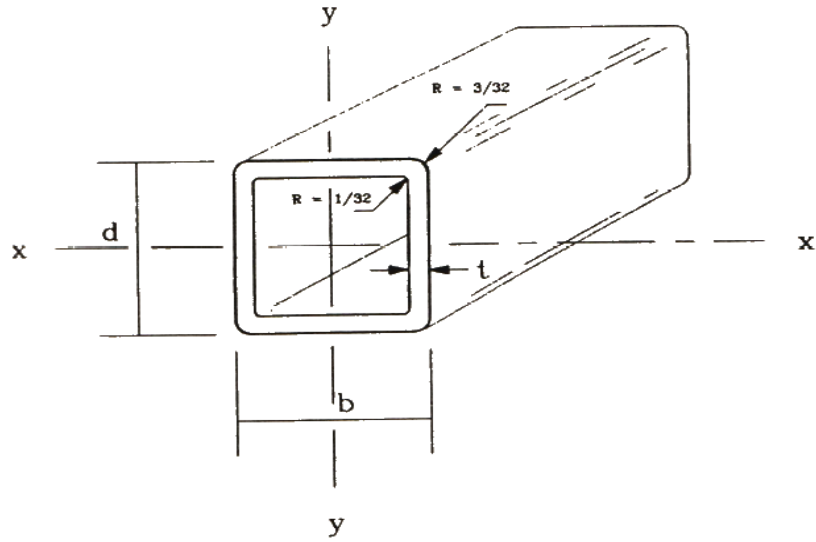

ROUND TUBE

SECTION DIMENSIONS				SECTION PROPERTIES		
od	t	A	Wt	I	S	r
in.	in.	in. ²	lb./ft.	in. ⁴	in. ³	in.
1	3/32	0.27	0.22	0.03	0.06	0.32
1	1/8	0.34	0.25	0.03	0.07	0.31
1	1/8	0.39	0.33	0.05	0.09	0.36
1	1/4	0.34	0.27	0.06	0.09	0.41
1	1/4	0.44	0.32	0.07	0.11	0.40
1	1/4	0.79	0.61	0.10	0.17	0.36
1	1/2	0.54	0.45	0.13	0.17	0.49
1	1/2	0.98	0.79	0.20	0.27	0.45
1	3/4	0.64	0.51	0.21	0.24	0.58
1	3/4	1.18	0.94	0.34	0.39	0.54
1	7/8	0.99	0.88	0.36	0.38	0.60
2	1/4	1.37	1.08	0.54	0.54	0.62
3	1/4	2.16	1.70	2.06	1.37	0.98
3	1/2	3.93	2.98	3.19	2.13	0.90

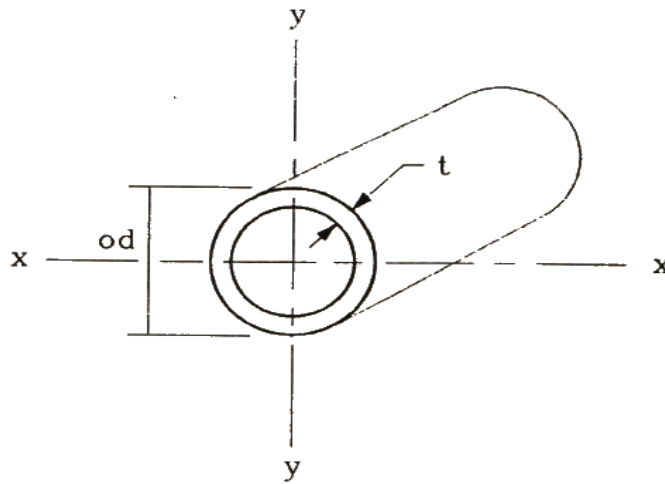

SQUARE BAR

SECTION DIMENSIONS				SECTION PROPERTIES					
d	b	A	Wt	X - X			Y - Y		
				I	S	r	I	S	r
in.	in.	in. ²	lb./ft.	in. ⁴	in. ³	in.	in. ⁴	in. ³	in.
1	1	1.00	0.88	0.08	0.17	0.29	0.08	0.17	0.29
1 1/4	1 1/4	1.56	1.37	0.20	0.33	0.36	0.20	0.33	0.36
1 1/2	1 1/2	2.25	1.98	0.42	0.56	0.43	0.42	0.56	0.43

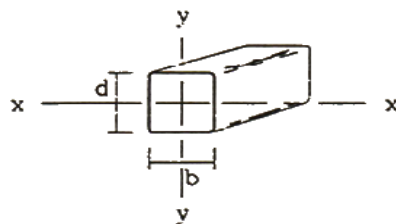

|b
y

SOLID ROUND

SECTION DIMENSIONS			SECTION PROPERTIES		
d	A	Wt	I	S	r
in.	in. ²	lb./ft.	in. ⁴	in. ³	in.
0.2500	0.049	0.044	0.0002	0.0016	0.0625
0.3000	0.071	0.062	0.0004	0.0027	0.0750
0.3125	0.077	0.067	0.0005	0.0030	0.0781
0.3500	0.096	0.083	0.0007	0.0042	0.0875
0.3750	0.110	0.095	0.0010	0.0052	0.0938
0.4375	0.150	0.133	0.0018	0.0082	0.1094
0.4720	0.175	0.150	0.0024	0.0103	0.1180
0.4800	0.181	0.160	0.0026	0.0109	0.1200
0.5000	0.196	0.172	0.0031	0.0123	0.1250
0.6250	0.307	0.270	0.0075	0.0240	0.1563
0.7500	0.442	0.397	0.0156	0.0414	0.1875
0.8125	0.518	0.460	0.0214	0.0527	0.2031
0.8750	0.601	0.534	0.0288	0.0658	0.2188
1.0000	0.785	0.697	0.0491	0.0982	0.2500
1.2500	1.227	1.094	0.1198	0.1917	0.3125
1.5000	1.766	1.571	0.2485	0.3313	0.3750

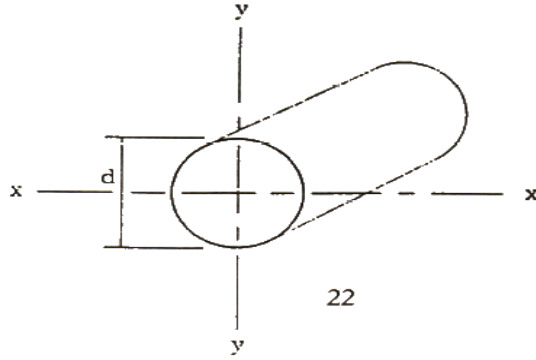

ALLOWABLE UNIFORM LOAD TABLE NOTATION

- A_w - Area of web (in²)
 δ - Deflection (in)
 E - Modulus of Elasticity (psi)
 F_b - Maximum Allowable Flexural Stress for Laterally Supported Beam (psi)
 F_v - Maximum Allowable Shear Stress for Laterally Supported Beam (psi)
 G - Shear Modulus (psi)
 I - Moment of Inertia (in⁴)
 L - Span Length (in)
 S - Section Modulus (in³)
 V - Vertical Shear (lbs)
 w - Uniform Load (lbs/in)
 M - Maximum Moment (in-lb)

The allowable uniform load tables were generated using the results from tests and the following formulas, properties, and assumptions. The Deflection formula reflects that the deflection is the result of both flexural and shear stresses.

$$\delta = \frac{5wL^4}{384EI} + \frac{wL^2}{4A_wG}$$

$$F_v = \frac{V}{A_w}$$

$$F_b = \frac{M}{S}$$

$$E = 2.8 \times 10^6 \text{ psi}$$

$$G = 450,000 \text{ psi}$$

$$F_b = 10,000 \text{ psi}$$

$$F_v = 1,500 \text{ psi}$$

Adequate lateral support is provided (full lateral support for channels).

Load is applied perpendicular to major axis.

Beam simply supported at both ends.

The part weight has been deduced in the following tables.

**ALLOWABLE UNIFORM LOADS (lbs./ft.)
Laterally Supported**

3 X 3 X 1/4 WIDE FLANGE BEAM
 $A_w=0.625 \text{ in}^2$ $I_x=3.17 \text{ in}^4$ $S_x=2.11 \text{ in}^3$ $Wt.=1.64 \text{ lbs./ft}$

SPAN FEET	MAXIMUM LOAD		DEFLECTION				
			L/100	L/150	L/180	L/240	L/360
3	623	F_v	*	*	*	496	330
4	467	F_v	*	388	323	242	161
5	373	F_v	322	214	178	133	88
6	311	F_v	194	129	107	80	53
7	266	F_v	125	83	69	51	33
8	218	F_v	85	56	46	34	22
9	172	F_v	60	39	32	24	15
10	139	F_v	43	28	23	17	11

The part weight has been deduced in the above table

4 X 4 X 1/4 WIDE FLANGE BEAM
 $A_w=0.875 \text{ in}^2$ $I_x=7.94 \text{ in}^4$ $S_x=3.97 \text{ in}^3$ $Wt.=2.15 \text{ lbs./ft}$

SPAN FEET	MAXIMUM LOAD		DEFLECTION				
			L/100	L/150	L/180	L/240	L/360
3	872	F_v	*	*	*	*	661
4	653	F_v	*	*	*	522	347
5	522	F_v	*	483	402	301	200
6	435	F_v	*	300	249	186	123
7	372	F_v	297	197	163	122	80
8	325	F_v	204	135	112	83	55
9	289	F_v	146	96	80	59	38
10	260	F_v	107	71	58	43	28
11	216	F_b	81	53	44	32	20
12	181	F_b	62	40	33	24	15
13	154	F_b	49	31	26	19	11

The part weight has been deduced in the above table

6 X 6 X 1/4 WIDE FLANGE BEAM
 $A_w=1.375 \text{ in}^2$ $I_x=28.28 \text{ in}^4$ $S_x=9.43 \text{ in}^3$ $Wt.=3.40 \text{ lbs./ft}$

SPAN FEET	MAXIMUM LOAD		DEFLECTION				
			L/100	L/150	L/180	L/240	L/360
5	821	F _v	*	*	*	*	554
6	684	F _v	*	*	*	549	364
7	585	F _v	*	*	503	377	250
8	512	F _v	*	430	358	267	177
9	454	F _v	*	315	262	195	129
10	409	F _v	357	237	196	146	96
11	371	F _v	274	181	150	112	73
12	450	F _v	215	142	117	87	57
13	313	F _v	171	112	93	69	44
14	219	F _v	138	90	75	55	35
15	271	F _v	112	74	61	44	28

The part weight has been deduced in the above table

6 X 6 X 3/8 WIDE FLANGE BEAM
 $A_w=1.969 \text{ in}^2$ $I_x=40.17 \text{ in}^4$ $S_x=13.39 \text{ in}^3$ $Wt.=4.90 \text{ lbs./ft}$

SPAN FEET	MAXIMUM LOAD		DEFLECTION				
			L/100	L/150	L/180	L/240	L/360
5	1176	F _v	*	*	*	*	790
6	980	F _v	*	*	*	782	520
7	839	F _v	*	*	717	537	356
8	733	F _v	*	613	510	381	252
9	651	F _v	*	449	373	279	184
10	586	F _v	508	337	280	209	138
11	532	F _v	390	259	215	160	105
12	487	F _v	306	202	168	124	81
13	449	F _v	243	160	133	98	64
14	417	F _v	196	129	107	79	51
15	389	F _v	160	0.5	87	64	41

The part weight has been deduced in the above table

8 X 8 X 3/8 WIDE FLANGE BEAM
 $A_w=2.719 \text{ in}^2$ $I_x=99.18 \text{ in}^4$ $S_x=24.80 \text{ in}^3$ $Wt.=6.49 \text{ lbs./ft}$

SPAN FEET	MAXIMUM LOAD		DEFLECTION				
			L/100	L/150	L/180	L/240	L/360
6	1353	F _v	*	*	*	*	1028
7	1158	F _v	*	*	*	1105	735
8	1013	F _v	*	*	*	811	539
9	899	F _v	*	*	815	609	404
10	809	F _v	*	751	625	467	309
11	735	F _v	*	586	488	364	240
12	673	F _v	*	465	387	288	190
13	620	F _v	565	374	311	231	152
14	576	F _v	461	305	253	188	123
15	537	F _v	380	251	208	154	100
16	503	F _v	316	209	173	128	83
17	473	F _v	266	175	145	107	69
18	446	F _v	225	148	122	90	58
19	422	F _v	192	126	104	76	48
20	401	F _v	165	108	89	65	41
21	368	F _b	143	93	76	55	35
22	335	F _b	124	80	66	48	29
23	306	F _b	108	70	57	41	25
24	280	F _b	95	61	50	35	21
25	258	F _b	83	53	43	31	18

The part weight has been deduced in the above table

8 X 8 X 1/2 WIDE FLANGE BEAM
 $A_w=3.500 \text{ in}^2$ $I_x=126.96 \text{ in}^4$ $S_x=31.74 \text{ in}^3$ $Wt.=8.70 \text{ lbs./ft}$

SPAN FEET	MAXIMUM LOAD		DEFLECTION				
			L/100	L/150	L/180	L/240	L/360
6	1741	F _v	*	*	*	*	1319
7	1491	F _v	*	*	*	1418	942
8	1304	F _v	*	*	*	1040	691
9	1158	F _v	*	*	1044	781	518
10	1041	F _v	*	963	801	598	396
11	946	F _v	*	751	625	466	308
12	866	F _v	*	596	495	369	243
13	799	F _v	724	479	398	296	194
14	741	F _v	590	390	324	241	157
15	691	F _v	486	321	266	197	129
16	647	F _v	405	267	221	164	106
17	609	F _v	341	224	185	137	88
18	574	F _v	288	189	156	115	74
19	544	F _v	246	161	133	97	62
20	516	F _v	211	138	113	83	52
21	471	F _b	183	119	97	71	44
22	428	F _b	159	103	84	61	38
23	391	F _b	138	89	73	52	32
24	385	F _b	121	78	63	45	27
25	330	F _b	107	68	55	39	23

The part weight has been deduced in the above table

10 X 10 X 1/2 WIDE FLANGE BEAM
 $A_w=4.500 \text{ in}^2$ $I_x=256.20 \text{ in}^4$ $S_x=51.24 \text{ in}^3$ $Wt.=10.90 \text{ lbs./ft}$

SPAN FEET	MAXIMUM LOAD		DEFLECTION				
			L/100	L/150	L/180	L/240	L/360
7	1918	F _v	*	*	*	*	1567
8	1677	F _v	*	*	*	*	1183
9	1489	F _v	*	*	*	1370	910
10	1339	F _v	*	*	*	1072	711
11	1216	F _v	*	*	1138	850	563
12	1114	F _v	*	1100	915	684	452
13	1027	F _v	*	896	745	556	367
14	953	F _v	*	738	613	457	301
15	889	F _v	*	614	510	379	249
16	833	F _v	778	515	427	318	208
17	783	F _v	658	435	361	268	175
18	739	F _v	562	371	307	228	148
19	700	F _v	482	318	263	195	126
20	664	F _v	417	274	227	167	108
21	632	F _v	362	238	196	144	93
22	603	F _v	316	207	171	125	80
23	576	F _v	278	181	149	109	69
24	552	F _v	245	160	131	96	60
25	529	F _v	217	141	115	84	52
26	494	F _b	192	125	102	74	46
27	458	F _b	172	111	90	65	40
28	425	F _b	153	99	80	57	35
29	395	F _b	138	88	72	51	30
30	369	F _b	124	79	64	45	26

The part weight has been deduced in the above table

12 X 12 X 1/2 WIDE FLANGE BEAM
 $A_w=5.500 \text{ in}^2$ $I_x=452.45 \text{ in}^4$ $S_x=75.45 \text{ in}^3$ $Wt.=13.20 \text{ lbs./ft}$

SPAN FEET	MAXIMUM LOAD		DEFLECTION				
			L/100	L/150	L/180	L/240	L/360
7	2343	F _v	*	*	*	*	2273
8	2049	F _v	*	*	*	*	1760
9	1819	F _v	*	*	*	*	1383
10	1636	F _v	*	*	*	*	1102
11	1486	F _v	*	*	*	1338	888
12	1361	F _v	*	*	*	1091	723
13	1255	F _v	*	*	1203	899	595
14	1165	F _v	*	*	1001	747	493
15	1086	F _v	*	1010	839	626	413
16	1017	F _v	*	854	710	529	348
17	957	F _v	*	728	604	450	295
18	903	F _v	*	624	518	385	252
19	854	F _v	814	538	446	331	216
20	811	F _v	707	467	387	287	186
21	772	F _v	618	407	337	249	161
22	736	F _v	542	357	295	218	140
23	703	F _v	478	314	259	191	123
24	674	F _v	423	277	229	168	107
25	646	F _v	376	246	203	148	94
26	621	F _v	335	219	180	131	83
27	597	F _v	300	195	160	117	73
28	575	F _v	269	175	143	104	65
29	555	F _v	242	157	128	93	57
30	536	F _v	219	141	115	83	51

The part weight has been deduced in the above table

3 X 1-1/2 X 1/2 I-BEAM
 $A_w=0.625 \text{ in}^2$ $I_x=1.75 \text{ in}^4$ $S_x=1.17 \text{ in}^3$ $Wt.=1.10 \text{ lbs./ft}$

SPAN FEET	MAXIMUM LOAD		DEFLECTION				
			L/100	L/150	L/180	L/240	L/360
3	623	F _v	*	511	425	319	212
4	467	F _v	355	236	196	147	97
5	310	F _b	189	126	104	78	51
6	215	F _b	112	74	61	45	30
7	157	F _b	71	46	38	28	18
8	120	F _b	47	31	25	19	12
9	94	F _b	33	21	17	13	8
10	76	F _b	24	15	12	9	5

The part weight has been deduced in the above table

4 X 2 X 1/4 I-BEAM
 $A_w=0.875 \text{ in}^2$ $I_x=4.41 \text{ in}^4$ $S_x=2.21 \text{ in}^3$ $Wt.=1.50 \text{ lbs./ft}$

SPAN FEET	MAXIMUM LOAD		DEFLECTION				
			L/100	L/150	L/180	L/240	L/360
3	873	F_v	*	*	*	692	461
4	654	F_v	*	542	451	338	225
5	523	F_v	449	299	249	186	123
6	407	F_b	271	180	150	112	74
7	299	F_b	175	116	96	72	47
8	228	F_b	119	78	65	48	32
9	180	F_b	84	55	46	34	22
10	145	F_b	61	40	33	24	16
11	120	F_b	46	30	25	18	11
12	100	F_b	35	23	19	13	8

The part weight has been deduced in the above table

6 X 3 X 1/4 I-BEAM
 $A_w=1.375 \text{ in}^2$ $I_x=16.99 \text{ in}^4$ $S_x=5.66 \text{ in}^3$ $Wt.=2.20 \text{ lbs./ft}$

SPAN FEET	MAXIMUM LOAD		DEFLECTION				
			L/100	L/150	L/180	L/240	L/360
5	822	F_v	*	*	797	597	397
6	685	F_v	*	607	505	378	251
7	586	F_v	*	405	337	252	167
8	513	F_v	424	282	234	175	116
9	455	F_v	306	203	169	126	83
10	374	F_b	227	150	125	93	61
11	309	F_b	173	114	95	70	46
12	259	F_b	134	88	73	54	35
13	220	F_b	106	70	57	42	27
14	189	F_b	85	56	46	34	21
15	165	F_b	69	45	37	27	17

The part weight has been deduced in the above table

6 X 3 X 3/8 I-BEAM
 $A_w=1.969 \text{ in}^2$ $I_x=22.35 \text{ in}^4$ $S_x=7.45 \text{ in}^3$ $Wt.=3.20 \text{ lbs./ft}$

SPAN FEET	MAXIMUM LOAD		DEFLECTION				
			L/100	L/150	L/180	L/240	L/360
6	981	F _v	*	813	676	506	336
7	840	F _v	812	540	449	336	223
8	734	F _v	564	375	312	233	154
9	609	F _b	406	269	224	167	110
10	493	F _b	301	199	165	123	81
11	406	F _b	229	151	125	93	61
12	341	F _b	177	117	97	72	46
13	290	F _b	140	92	76	56	36
14	249	F _b	112	73	60	44	28
15	217	F _b	91	59	49	36	22
16	190	F _b	75	48	40	29	18
17	168	F _b	62	40	33	23	14
18	149	F _b	52	33	27	19	11

The part weight has been deduced in the above table

8 X 4 X 3/8 I-BEAM
 $A_w=2.719 \text{ in}^2$ $I_x=55.55 \text{ in}^4$ $S_x=13.89 \text{ in}^3$ $Wt.=4.30 \text{ lbs./ft}$

SPAN FEET	MAXIMUM LOAD		DEFLECTION				
			L/100	L/150	L/180	L/240	L/360
6	1355	F _v	*	*	*	1083	720
7	1160	F _v	*	*	993	744	494
8	1015	F _v	*	849	707	529	351
9	901	F _v	*	622	518	387	256
10	811	F _v	704	468	389	291	192
11	737	F _v	542	359	299	223	147
12	638	F _b	425	281	234	174	114
13	543	F _b	338	224	186	138	90
14	467	F _b	273	181	150	111	72
15	407	F _b	224	147	122	90	58
16	357	F _b	185	122	101	74	48
17	315	F _b	154	101	84	61	39
18	281	F _b	130	85	70	51	33
19	251	F _b	111	72	59	43	27
20	226	F _b	94	61	50	36	23

The part weight has been deduced in the above table

8 X 4 X 1/2 I-BEAM
 $A_w=3.500 \text{ in}^2$ $I_x=70.62 \text{ in}^4$ $S_x=17.66 \text{ in}^3$ $Wt.=5.70 \text{ lbs./ft}$

SPAN FEET	MAXIMUM LOAD		DEFLECTION				
			L/100	L/150	L/180	L/240	L/360
6	1744	F _v	*	*	*	1383	920
7	1494	F _v	*	*	1267	949	631
8	1307	F _v	*	1082	901	674	448
9	1161	F _v	*	793	660	494	327
10	1044	F _v	897	596	496	370	245
11	949	F _v	690	458	381	284	187
12	812	F _b	541	358	298	222	146
13	691	F _b	431	285	237	176	115
14	595	F _b	348	230	191	142	92
15	517	F _b	285	188	156	115	75
16	454	F _b	236	155	128	95	61
17	401	F _b	197	129	107	79	50
18	357	F _b	166	109	90	66	42
19	320	F _b	141	92	76	55	35
20	288	F _b	121	78	64	47	29

The part weight has been deduced in the above table

10 X 5 X 1/2 I-BEAM
 $A_w=4.500 \text{ in}^2$ $I_x=143.29 \text{ in}^4$ $S_x=28.66 \text{ in}^3$ $Wt.=7.20 \text{ lbs./ft}$

SPAN FEET	MAXIMUM LOAD		DEFLECTION				
			L/100	L/150	L/180	L/240	L/360
6	2242	F _v	*	*	*	*	1579
7	1921	F _v	*	*	*	1681	1118
8	1680	F _v	*	*	1635	1225	814
9	1492	F _v	*	1468	1222	914	607
10	1342	F _v	*	1120	932	697	462
11	1219	F _v	*	872	725	542	359
12	1117	F _v	1038	690	573	428	283
13	1030	F _v	834	554	460	343	226
14	956	F _v	679	450	374	278	183
15	841	F _b	599	370	307	228	150
16	738	F _b	466	308	255	189	124
17	653	F _b	391	258	214	158	103
18	582	F _b	331	218	180	133	86
19	521	F _b	283	186	153	113	73
20	470	F _b	243	159	131	97	62
21	425	F _b	210	137	113	83	53
22	387	F _b	183	119	98	71	45
23	353	F _b	160	104	85	62	39
24	324	F _b	140	91	74	54	33
25	298	F _b	123	80	65	47	28

The part weight has been deduced in the above table

10 X 5 X 3/8 I-BEAM
 $A_w=3.469 \text{ in}^2$ $I_x=111.63 \text{ in}^4$ $S_x=22.33 \text{ in}^3$ $Wt.=5.78 \text{ lbs./ft}$

SPAN FEET	MAXIMUM LOAD		DEFLECTION				
			L/100	L/150	L/180	L/240	L/360
6	1728	F _v	*	*	*	*	1225
7	1481	F _v	*	*	*	1305	868
8	1295	F _v	*	*	1270	951	632
9	1150	F _v	*	1141	949	711	472
10	1035	F _v	*	871	725	542	359
11	940	F _v	*	678	564	422	279
12	861	F _v	808	537	446	333	220
13	794	F _v	649	431	358	267	176
14	737	F _v	529	350	291	217	143
15	656	F _b	436	288	239	178	117
16	575	F _b	363	240	199	148	96
17	509	F _b	305	201	167	123	80
18	453	F _b	258	170	141	104	67
19	406	F _b	220	145	120	88	57
20	366	F _b	189	124	103	75	48
21	332	F _b	164	107	88	65	41
22	302	F _b	142	93	76	56	35
23	275	F _b	124	81	66	48	30
24	252	F _b	109	71	58	42	26
25	232	F _b	96	62	51	37	22

The part weight has been deduced in the above table

12 X 6 X 1/2 I-BEAM
 $A_w=5.50 \text{ in}^2$ $I_x=253.96 \text{ in}^4$ $S_x=42.33 \text{ in}^3$ $Wt.=8.70 \text{ lbs./ft}$

SPAN FEET	MAXIMUM LOAD		DEFLECTION				
			L/100	L/150	L/180	L/240	L/360
6	2741	F _v	*	*	*	*	3254
7	2348	F _v	*	*	*	*	1715
8	2054	F _v	*	*	*	1922	1278
9	1824	F _v	*	*	*	1463	972
10	1641	F _v	*	*	1514	1134	753
11	1491	F _v	*	1434	1193	893	592
12	1366	F _v	*	1147	954	713	473
13	1260	F _v	*	929	773	577	382
14	1170	F _v	1147	762	633	473	312
15	1091	F _v	951	631	524	391	258
16	1022	F _v	796	528	438	327	215
17	962	F _v	673	445	370	275	180
18	862	F _b	573	379	314	233	153
19	773	F _b	491	324	269	199	130
20	696	F _b	424	279	231	171	111
21	631	F _b	368	242	200	148	96
22	574	F _b	321	211	174	129	83
23	524	F _b	282	185	152	112	72
24	481	F _b	248	162	134	98	62
25	442	F _b	220	143	118	86	55
26	408	F _b	195	127	104	76	48
27	378	F _b	174	113	93	67	42
28	351	F _b	156	101	83	60	37
29	327	F _b	140	90	74	53	32
30	305	F _b	126	81	66	47	28

The part weight has been deduced in the above table

18 X 3/8 X 4 1/2 X 1/2 I-BEAM
 $A_w=6.375 \text{ in}^2$ $I_x=498.15 \text{ in}^4$ $S_x=55.35 \text{ in}^3$ $Wt.=8.70 \text{ lbs./ft}$

SPAN FEET	MAXIMUM LOAD		DEFLECTION				
			L/100	L/150	L/180	L/240	L/360
8	2382	F _v	*	*	*	*	1996
9	2116	F _v	*	*	*	*	1565
10	1904	F _v	*	*	*	1872	1245
11	1730	F _v	*	*	*	1507	1002
12	1585	F _v	*	*	*	1228	816
13	1462	F _v	*	*	1351	1011	671
14	1357	F _v	*	1349	1123	840	557
15	1266	F _v	*	1132	942	704	466
16	1186	F _v	*	957	796	595	394
17	1116	F _v	*	815	678	506	335
18	1054	F _v	*	700	581	434	286
19	998	F _v	910	604	502	374	246
20	913	F _b	791	524	436	324	213
21	828	F _b	691	458	380	283	186
22	753	F _b	607	402	333	248	162
23	688	F _b	536	354	294	218	142
24	632	F _b	475	313	260	193	125
25	581	F _b	422	279	231	171	111
26	537	F _b	377	248	206	152	98
27	497	F _b	338	222	184	136	87
28	462	F _b	304	200	165	121	78
29	430	F _b	274	180	148	109	70
30	401	F _b	248	162	134	98	62

The part weight has been deduced in the above table

24 X 3/8 X 7 1/2 X 3/4 I-BEAM
 $A_w=8.44 \text{ in}^2$ $I_x=1877 \text{ in}^4$ $S_x=156.42 \text{ in}^3$ $Wt.=15.20 \text{ lbs./ft}$

SPAN FEET	MAXIMUM LOAD		DEFLECTION				
			L/100	L/150	L/180	L/240	L/360
35	707	F _v	552	363	300	221	142
36	687	F _v	510	335	276	203	130
37	668	F _v	472	309	255	187	119
38	650	F _v	437	286	236	173	110
39	633	F _v	405	265	218	160	101
40	617	F _v	377	246	202	148	93
41	602	F _v	350	228	188	137	86
42	575	F _b	327	212	174	127	79
43	548	F _b	305	198	162	118	73
44	523	F _b	284	184	151	109	67
45	499	F _b	266	172	141	101	62
46	477	F _b	249	161	131	94	58
47	456	F _b	233	150	122	88	53
48	437	F _b	219	140	114	82	49
49	418	F _b	205	131	107	76	45
50	401	F _b	193	123	100	71	42
51	385	F _b	181	116	94	66	39
52	370	F _b	171	108	88	62	36
53	355	F _b	161	102	82	58	33
54	342	F _b	151	96	77	54	31
55	329	F _b	143	90	72	50	28
56	316	F _b	135	84	68	47	26
57	305	F _b	127	79	64	44	24

The part weight has been deduced in the above table

3 X 13/16 X 1/8 CHANNEL
 $A_w=0.344 \text{ in}^2$ $I_x=0.64 \text{ in}^4$ $S_x=0.43 \text{ in}^3$ $Wt.=0.43 \text{ lbs./ft}$

SPAN FEET	MAXIMUM LOAD		DEFLECTION				
			L/100	L/150	L/180	L/240	L/360
3	317	F _b	301	200	167	125	83
4	178	F _b	135	90	75	56	37
5	114	F _b	71	47	39	29	19
6	79	F _b	41	27	23	17	11
7	57	F _b	26	17	14	10	7
8	44	F _b	17	11	9	7	4
9	34	F _b	12	8	6	4	3
10	28	F _b	8	5	4	3	2

The part weight has been deduced in the above table

3 X 1 X 1/4 CHANNEL
 $A_w=0.625 \text{ in}^2$ $I_x=1.27 \text{ in}^4$ $S_x=0.85 \text{ in}^3$ $Wt.=0.85 \text{ lbs./ft}$

SPAN FEET	MAXIMUM LOAD		DEFLECTION				
			L/100	L/150	L/180	L/240	L/360
3	624	F _v	591	393	328	246	163
4	353	F _b	267	178	148	111	73
5	226	F _b	141	94	78	58	38
6	156	F _b	83	55	46	34	22
7	115	F _b	52	35	29	21	14
8	88	F _b	35	23	19	14	9
9	69	F _b	24	16	13	10	6
10	56	F _b	18	11	9	7	4

The part weight has been deduced in the above table

3 X 1 1/2 X 1/4 CHANNEL
 $A_w=0.625 \text{ in}^2$ $I_x=1.75 \text{ in}^4$ $S_x=1.16 \text{ in}^3$ $Wt.=1.01 \text{ lbs./ft}$

SPAN FEET	MAXIMUM LOAD		DEFLECTION				
			L/100	L/150	L/180	L/240	L/360
3	623	F _v	*	511	425	319	212
4	467	F _v	355	236	196	147	97
5	307	F _b	189	126	104	78	51
6	213	F _b	112	74	61	45	30
7	156	F _b	71	46	38	28	18
8	119	F _b	47	31	25	19	12
9	93	F _b	33	21	17	13	8
10	75	F _b	24	15	12	9	5

The part weight has been deduced in the above table

3 1/2 X 1 3/16 X 1/8 X 3/16 CHANNEL
 $A_w=0.406 \text{ in}^2$ $I_x=1.54 \text{ in}^4$ $S_x=0.88 \text{ in}^3$ $Wt.=0.67 \text{ lbs./ft}$

SPAN FEET	MAXIMUM LOAD		DEFLECTION				
			L/100	L/150	L/180	L/240	L/360
3	623	F _v	*	511	425	319	212
4	467	F _v	355	236	196	147	97
5	307	F _b	189	126	104	78	51
6	213	F _b	112	74	61	45	30
7	156	F _b	71	46	38	28	18
8	119	F _b	47	31	25	19	12
9	93	F _b	33	21	17	13	8
10	75	F _b	24	15	12	9	5

The part weight has been deduced in the above table

4 X 1 3/8 X 3/16 CHANNEL
 $A_w=0.680 \text{ in}^2$ $I_x=2.62 \text{ in}^4$ $S_x=1.31 \text{ in}^3$ $Wt.=0.88 \text{ lbs./ft}$

SPAN FEET	MAXIMUM LOAD		DEFLECTION				
			L/100	L/150	L/180	L/240	L/360
3	679	F _v	*	*	593	445	296
4	509	F _v	509	339	282	211	141
5	348	F _b	277	184	153	115	76
6	242	F _b	165	110	91	68	45
7	177	F _b	106	70	58	44	29
8	135	F _b	72	48	39	29	19
9	107	F _b	51	33	28	21	13
10	86	F _b	37	24	20	15	10

The part weight has been deduced in the above table

4 X 1 1/8 X 1/4 CHANNEL
 $A_w=0.875 \text{ in}^2$ $I_x=2.87 \text{ in}^4$ $S_x=1.44 \text{ in}^3$ $Wt.=1.05 \text{ lbs./ft}$

SPAN FEET	MAXIMUM LOAD		DEFLECTION				
			L/100	L/150	L/180	L/240	L/360
3	873	F _v	*	811	675	506	337
4	598	F _b	570	380	316	236	157
5	382	F _b	307	204	170	127	84
6	265	F _b	182	121	100	75	49
7	194	F _b	116	77	64	47	31
8	148	F _b	78	52	43	31	20
9	117	F _b	55	36	30	22	14
10	94	F _b	40	26	21	15	10

The part weight has been deduced in the above table

6 X 1 5/8 X 1/4 CHANNEL
 $A_w=1.375 \text{ in}^2$ $I_x=10.18 \text{ in}^4$ $S_x=3.39 \text{ in}^3$ $Wt.=1.67 \text{ lbs./ft}$

SPAN FEET	MAXIMUM LOAD		DEFLECTION				
			L/100	L/150	L/180	L/240	L/360
5	823	F _v	*	649	540	405	269
6	626	F _b	599	399	332	249	165
7	459	F _b	392	261	217	162	107
8	351	F _b	269	179	149	111	73
9	277	F _b	192	127	106	79	52
10	224	F _b	141	93	78	58	38
11	185	F _b	107	70	58	43	28
12	155	F _b	82	54	45	33	21
13	132	F _b	65	43	35	26	17
14	113	F _b	52	34	28	20	13
15	98	F _b	42	27	22	16	10

The part weight has been deduced in the above table

6 X 1 11/16 X 3/8 CHANNEL
 $A_w=1.969 \text{ in}^2$ $I_x=14.55 \text{ in}^4$ $S_x=4.86 \text{ in}^3$ $Wt.=2.39 \text{ lbs./ft}$

SPAN FEET	MAXIMUM LOAD		DEFLECTION				
			L/100	L/150	L/180	L/240	L/360
5	1178	F_v	*	928	773	579	385
6	895	F_b	857	570	475	355	236
7	657	F_b	560	372	310	232	153
8	502	F_b	384	255	212	158	105
9	396	F_b	274	182	151	112	74
10	320	F_b	202	133	111	82	54
11	264	F_b	152	101	83	62	40
12	222	F_b	118	77	64	47	31
13	188	F_b	92	61	50	37	24
14	162	F_b	74	48	40	29	18
15	141	F_b	60	39	32	23	14

The part weight has been deduced in the above table

8 X 2-3/16 X 3/8 CHANNEL
 $A_w=2.719 \text{ in}^2$ $I_x=35.77 \text{ in}^4$ $S_x=8.94 \text{ in}^3$ $Wt.=3.20 \text{ lbs./ft}$

SPAN FEET	MAXIMUM LOAD		DEFLECTION				
			L/100	L/150	L/180	L/240	L/360
5	1627	F_v	*	*	*	1235	822
6	1356	F_v	*	1261	1050	787	523
7	1161	F_v	*	845	704	527	350
8	927	F_b	887	590	491	367	244
9	732	F_b	642	426	355	265	175
10	592	F_b	478	317	264	197	130
11	489	F_b	364	241	201	149	98
12	410	F_b	283	188	156	116	76
13	349	F_b	224	148	123	91	59
14	300	F_b	180	119	98	73	47
15	261	F_b	147	97	80	59	38
16	229	F_b	121	79	65	48	31
17	202	F_b	101	66	54	40	25
18	180	F_b	85	55	45	33	21
19	161	F_b	72	46	38	27	17
20	145	F_b	61	39	32	23	14

The part weight has been deduced in the above table

10 X 2-3/4 X 1/2 CHANNEL
 $A_w=4.500 \text{ in}^2$ $I_x=92.49 \text{ in}^4$ $S_x=18.50 \text{ in}^3$ $Wt.=5.30 \text{ lbs./ft}$

SPAN FEET	MAXIMUM LOAD		DEFLECTION				
			L/100	L/150	L/180	L/240	L/360
6	2244	F _v	*	*	*	1802	1199
7	1923	F _v	*	*	1654	1239	824
8	1682	F _v	*	1414	1177	882	586
9	1494	F _v	*	1037	864	646	429
10	1227	F _b	1174	781	650	486	322
11	1013	F _b	904	600	499	373	247
12	850	F _b	709	470	391	292	193
13	724	F _b	565	375	311	232	153
14	623	F _b	457	303	251	187	123
15	542	F _b	374	248	205	153	100
16	476	F _b	310	205	170	126	82
17	421	F _b	259	171	141	105	68
18	375	F _b	219	144	119	88	56
19	336	F _b	186	122	101	74	47
20	302	F _b	160	104	86	63	40
21	274	F _b	138	90	74	54	34
22	249	F _b	119	78	64	46	29
23	227	F _b	104	67	55	40	25
24	208	F _b	91	59	48	34	21
25	191	F _b	80	51	42	30	18

The part weight has been deduced in the above table

3 X 1/4 SQUARE TUBE
 $A_w=1.250 \text{ in}^2$ $I_x=3.50 \text{ in}^4$ $S_x=2.33 \text{ in}^3$ $Wt.=2.07 \text{ lbs./ft}$

SPAN FEET	MAXIMUM LOAD		DEFLECTION				
			L/100	L/150	L/180	L/240	L/360
4	935	F _v	710	472	393	294	195
5	618	F _b	380	252	210	156	103
6	428	F _b	224	149	123	92	60
7	314	F _b	142	94	78	58	37
8	240	F _b	96	63	52	38	24
9	189	F _b	67	43	36	26	16
10	152	F _b	48	31	25	18	11
11	125	F _b	36	23	18	13	8
12	105	F _b	27	17	14	9	5

The part weight has been deduced in the above table

4 X 1/4 SQUARE TUBE
 $A_w=1.750 \text{ in}^2$ $I_x=8.82 \text{ in}^4$ $S_x=4.41 \text{ in}^3$ $Wt.=2.83 \text{ lbs./ft}$

SPAN FEET	MAXIMUM LOAD		DEFLECTION				
			L/100	L/150	L/180	L/240	L/360
4	1310	F _v	*	1085	903	677	450
5	1047	F _v	900	599	499	373	248
6	814	F _b	543	361	301	225	149
7	597	F _b	351	233	194	144	95
8	456	F _b	238	158	131	98	64
9	360	F _b	169	112	92	69	45
10	291	F _b	123	81	67	50	32
11	240	F _b	93	61	50	37	24
12	201	F _b	71	46	38	28	18
13	171	F _b	56	36	30	21	13
14	147	F _b	44	28	23	17	10
15	128	F _b	35	23	18	13	8

The part weight has been deduced in the above table

Introduction To Columns and Column tables

COLUMNS

Full section column testing was conducted on equal leg angles, I-Beams, Wide Flange Beams and Square Tubes. Ultimate values were generated through testing of elements with square cut ends placed between the table and the upper, moving platen of a universal testing machine. This test procedure closely simulates how FRP columns will generally be used in practice. Comparison of test data versus theoretical Euler buckling capacity suggests that the "K" value as tested is approximately 0.70, representing a fixed-pinned condition. The values in the tables represent a FS=3.0 for the tested condition. Should you feel, however, that your column end conditions closely approximate a pinned-pinned condition ("rounded" column ends are somewhat difficult to achieve in practice) we recommend you multiply the allowable values shown by the following values:

SHAPE	To Obtain FS=2.0 multiply by:	To Obtain FS=3.0 multiply by:
I, W or Angle	0.75	0.50
Square Tube	0.50	0.33

COLUMN TABLES

- A - area (in²)
- b - width of flange/leg/wall (in)
- t - thickness of flange (in)
- r - minimum radius gyration (in)
- l - length (in)
- K - effective column length factor
- F_a - allowable column concentric axial stress (psi)
- P_a - allowable column concentric axial stress (lbs)

Angle

Maximum allowable stress:

b/t ! 8	4,862 psi
b/t = 10.7	4,194 psi
b/t = 12	3,620 psi
b/t = 16	2,758 psi

Square tube (1/4" wall)

Maximum allowable stress:

b/t ! 10	10,000 psi
b/t = 12	8,880 psi
b/t = 16	6,595 psi

Wide-Flange & I-Beam

Maximum allowable stress:

	b/t ! 12	10,000 psi
	b/t = 13.3	8,747 psi
t = 1/4"	b/t = 16	7,208 psi
t > 1/4"	b/t = 16	6,233 psi
	b/t = 20	4,920 psi
	b/t = 21.3	4,483 psi
t = 1/4"	b/t = 24	4,167 psi
t > 1/4"	b/t = 24	3,608 psi
	b/t = 26.7	2,732 psi

Column Tables
Allowable Concentric Axial Stresses and Loads

2 X 2 X 1/4 ANGLE

A = 0.92 in²
r = 0.38 in
b/t = 8

TRUE LENGTH (ft)	F _a (psi)	P _a (lbs)
0.5	4.862	4.473
1.0	2.807	2.582
1.5	2.077	1.911
2.0	1.684	1.549
2.5	1.416	1.303
3.0	1.211	1.114
3.5	1.079	993
4.0	988	909
4.5	891	820
5.0	833	766
5.5	752	692
6.0	667	614

The effective 'K' value is 0.70. 'K' equals effective column length factor. See introduction to column tables showing notation factors

3 X 3 X 1/4 ANGLE

A = 1.42 in²
r = 0.9 in
b/t = 12

TRUE LENGTH (ft)	F _a (psi)	P _a (lbs)
0.5	3.620	5.140
1.0	3.620	5.140
1.5	2.933	4.165
2.0	2.277	3.233
2.5	1.968	2.795
3.0	1.736	2.465
3.5	1.538	2.184
4.0	1.391	1.975
4.5	1.249	1.774
5.0	1.146	1.627
5.5	1.070	1.519
6.0	1.010	1.434
6.5	952	1.352
7.0	889	1.262
7.5	849	1.206
8.0	815	1.157
8.5	757	1.075
9.0	708	1.005
9.5	665	944

The effective 'K' value is 0.70. 'K' equals effective column length factor. See introduction to column tables showing notation factors

3 X 3 X 3/8 ANGLE

$A = 2.09 \text{ in}^2$

$r = 0.59 \text{ in}$

$b/t = 8$

TRUE LENGTH (ft)	F _a (psi)	P _a (lbs)
0.5	4.862	10.162
1.0	4.862	10.162
1.5	2.933	6.130
2.0	2.277	4.756
2.5	1.968	4.113
3.0	1.736	3.628
3.5	1.538	3.214
4.0	1.391	2.907
4.5	1.249	2.610
5.0	1.146	2.395
5.5	1.070	2.236
6.0	1.010	2.111
6.5	952	1.990
7.0	889	1.858
7.5	849	1.774
8.0	815	1.703
8.5	757	1.582
9.0	708	1.480
9.5	665	1.390

The effective 'K' value is 0.70. 'K' equals effective column length factor. See introduction to column tables showing notation factors

3 X 3 X 1/2 ANGLE

$A = 2.70 \text{ in}^2$

$r = 0.59 \text{ in}$

$b/t = 6$

TRUE LENGTH (ft)	F _a (psi)	P _a (lbs)
0.5	4.862	13.127
1.0	4.862	13.127
1.5	2.933	7.919
2.0	2.277	6.148
2.5	1.968	5.314
3.0	1.736	4.687
3.5	1.538	4.153
4.0	1.391	3.756
4.5	1.249	3.372
5.0	1.146	3.094
5.5	1.070	2.889
6.0	1.010	2.727
6.5	952	2.570
7.0	889	2.400
7.5	849	2.292
8.0	815	2.201
8.5	757	2.044
9.0	708	1.912
9.5	665	1.796

The effective 'K' value is 0.70. 'K' equals effective column length factor. See introduction to column tables showing notation factors

4 X 4 X 1/4 ANGLE

$A = 1.92 \text{ in}^2$

$r = 0.80 \text{ in}$

$b/t = 16$

TRUE LENGTH (ft)	F _a (psi)	P _a (lbs)
0.5	2,758	5,295

1.0	2.758	5.295
1.5	2.758	5.295
2.0	2.758	5.295
2.5	2.393	4.595
3.0	2.133	4.095
3.5	1.914	3.675
4.0	1.760	3.379
4.5	1.603	3.078
5.0	1.482	2.845
5.5	1.379	2.648
6.0	1.283	2.463
6.5	1.187	2.279
7.0	1.123	2.156
7.5	1.064	2.043
8.0	1.020	1.958
8.5	980	1.882
9.0	933	1.791
9.5	889	1.707
10.0	860	1.651
10.5	834	1.601
11.0	802	1.540
11.5	759	1.457
12.0	727	1.396
12.5	693	1.331
13.0	660	1.267

The effective 'K' value is 0.70. 'K' equals effective column length factor. See introduction to column tables showing notation factors

4 X 4 X 3/8 ANGLE

$A = 2.84 \text{ in}^2$

$r = 0.79 \text{ in}$

$b/t = 10.7$

TRUE LENGTH (ft)	F_a (psi)	P_a (lbs)
0.5	4,194	11,911
1.0	4,194	11,911
1.5	4,194	11,911
2.0	2,947	8,369
2.5	2,367	6,722
3.0	2,113	6,001
3.5	1,896	5,385
4.0	1,741	4,944
4.5	1,586	4,504
5.0	1,461	4,149
5.5	1,364	3,874
6.0	1,260	3,578
6.5	1,177	3,343
7.0	1,113	3,161
7.5	1,048	2,976
8.0	1,012	2,874
8.5	969	2,752
9.0	922	2,618
9.5	878	2,494
10.0	853	2,423
10.5	828	2,352
11.0	791	2,246
11.5	745	2,116
12.0	712	2,022
12.5	680	1,931
13.0	652	1,852

The effective 'K' value is 0.70. 'K' equals effective column length factor. See introduction to column tables showing notation factors

6 X 6 X 3/8 ANGLE

$A = 4.33 \text{ in}^2$

$r = 1.14 \text{ in}$

$b/t = 16$

TRUE LENGTH (ft)	F_a (psi)	P_a (lbs)
0.5	2.758	11.942
1.0	2.758	11.942
1.5	2.758	11.942
2.0	2.758	11.942
2.5	2.758	11.942
3.0	2.758	11.942
3.5	2.427	10.509
4.0	2.229	9.652
4.5	2.060	8.920
5.0	1.911	8.275
5.5	1.802	7.803
6.0	1.684	7.292
6.5	1.585	6.863
7.0	1.503	6.508
7.5	1.416	6.131
8.0	1.354	5.863
8.5	1.289	5.581
9.0	1.211	5.244
9.5	1.167	5.053
10.0	1.121	4.854
10.5	1.079	4.672
11.0	1.041	4.508
11.5	1.015	4.395
12.0	988	4.278
12.5	955	4.135
13.0	922	3.992
13.5	892	3.862
14.0	872	3.776
14.5	851	3.685
15.0	833	3.607
15.5	813	3.520
16.0	782	3.386
16.5	752	3.256
17.0	729	3.157
17.5	706	3.057
18.0	680	2.944
18.5	660	2.858

The effective 'K' value is 0.70. 'K' equals effective column length factor. See introduction to column tables showing notation factors

6 X 6 X 1/2 ANGLE

A = 5.70 in²

r = 1.19 in

b/t = 12

TRUE LENGTH (ft)	F _a (psi)	P _a (lbs)
0.5	3.620	20.634
1.0	3.620	20.634
1.5	3.620	20.634
2.0	3.620	20.634
2.5	3.620	20.634
3.0	2.960	16.872
3.5	2.512	14.318
4.0	2.290	13.053
4.5	2.120	12.084
5.0	1.984	11.309
5.5	1.844	10.511
6.0	1.748	9.964
6.5	1.642	9.359
7.0	1.548	8.824
7.5	1.469	8.373
8.0	1.397	7.963
8.5	1.337	7.621
9.0	1.267	7.222
9.5	1.202	6.851
10.0	1.157	6.595
10.5	1.117	6.367
11.0	1.076	6.133
11.5	1.033	5.888
12.0	1.015	5.786
12.5	989	5.637
13.0	958	5.461
13.5	927	5.284
14.0	896	5.107
14.5	873	4.976
15.0	855	4.874
15.5	839	4.782
16.0	822	4.685
16.5	794	4.526
17.0	765	4.361
17.5	737	4.201
18.0	717	4.087
18.5	699	3.984
19.0	672	3.830
19.5	655	3.734

The effective 'K' value is 0.70. 'K' equals effective column length factor. See introduction to column tables showing notation factors

3 X 1-1/2 X 1/4 I-BEAM

$A = 1.38 \text{ in}^2$

$r = 0.32 \text{ in}$

$b/t = 6$

TRUE LENGTH (ft)	F_a (psi)	P_a (lbs)
0.5	10.000	13.800
1.0	8.121	11.207
1.5	5.155	7.114
2.0	3.583	4.945
2.5	2.462	3.398
3.0	1.683	2.323
3.5	1.278	1.764
4.0	1.027	1.417
4.5	843	1.163
5.0	652	900

The effective 'K' value is 0.70. 'K' equals effective column length factor. See introduction to column tables showing notation factors

4 X 2 X 1/4 I-BEAM

$A = 1.88 \text{ in}^2$

$r = 0.43 \text{ in}$

$b/t = 8$

TRUE LENGTH (ft)	F_a (psi)	P_a (lbs)
0.5	10.000	18.800
1.0	10.000	18.800
1.5	7.107	13.361
2.0	5.206	9.787
2.5	4.061	7.635
3.0	3.017	5.672
3.5	2.248	4.226
4.0	1.717	3.228
4.5	1.373	2.581
5.0	1.147	2.156
5.5	992	1.865
6.0	854	1.606
6.5	713	1.340
7.0	567	1.066

The effective 'K' value is 0.70. 'K' equals effective column length factor. See introduction to column tables showing notation factors

6 X 3 X 1/4 I-BEAM

$A = 2.88 \text{ in}^2$

$r = 0.63 \text{ in}$

$b/t = 12$

TRUE LENGTH (ft)	F_a (psi)	P_a (lbs)
0.5	10.000	28.800
1.0	10.000	28.800
1.5	10.000	28.800
2.0	7.944	22.879
2.5	6.127	17.646
3.0	5.083	14.639
3.5	4.255	12.254
4.0	3.486	10.040
4.5	2.886	8.312
5.0	2.380	6.854
5.5	1.974	5.685
6.0	1.623	4.674
6.5	1.403	4.041
7.0	1.245	3.586
7.5	1.105	3.182
8.0	1.003	2.889
8.5	908	2.615
9.0	817	2.353
9.5	717	2.065
10.0	615	1.771
10.5	520	1.498

The effective 'K' value is 0.70. 'K' equals effective column length factor. See introduction to column tables showing notation factors

6 X 3 X 3/8 I-BEAM

$A = 4.23 \text{ in}^2$

$r = 0.64 \text{ in}$

$b/t = 8$

TRUE LENGTH (ft)	F_a (psi)	P_a (lbs)
0.5	10.000	42.300
1.0	10.000	42.300
1.5	10.000	42.300
2.0	7.700	32.571
2.5	5.415	22.905
3.0	4.237	17.923
3.5	3.450	14.594
4.0	2.833	11.984
4.5	2.297	9.716
5.0	1.843	7.796
5.5	1.563	6.611
6.0	1.347	5.698
6.5	1.169	4.945
7.0	1.050	4.442
7.5	923	3.904
8.0	800	3.384
8.5	721	3.050
9.0	647	2.737
9.5	586	2.479
10.0	525	2.221
10.5	479	2.026

The effective 'K' value is 0.70. 'K' equals effective column length factor. See introduction to column tables showing notation factors

8 X 4 X 3/8 I-BEAM

$A = 5.73 \text{ in}^2$

$r = 0.84 \text{ in}$

$b/t = 10.7$

TRUE LENGTH (ft)	F_a (psi)	P_a (lbs)
0.5	10.000	57.300
1.0	10.000	57.300
1.5	10.000	57.300
2.0	10.000	57.300
2.5	8.370	47.960
3.0	6.182	35.423
3.5	4.917	28.174
4.0	4.157	23.820
4.5	3.558	20.387
5.0	3.063	17.551
5.5	2.598	14.887
6.0	2.232	12.789
6.5	1.888	10.818
7.0	1.667	9.552
7.5	1.461	8.372
8.0	1.311	7.512
8.5	1.176	6.738
9.0	1.085	6.217
9.5	997	5.713
10.0	888	5.088
10.5	800	4.584
11.0	741	4.246
11.5	680	3.896
12.0	630	3.610
12.5	582	3.335
13.0	535	3.066
13.5	498	2.854
14.0	467	2.676

The effective 'K' value is 0.70. 'K' equals effective column length factor. See introduction to column tables showing notation factors

8 X 4 X 1/2 I-BEAM

$A = 7.51 \text{ in}^2$

$r = 0.85 \text{ in}$

$b/t = 8$

TRUE LENGTH (ft)	F_a (psi)	P_a (lbs)
0.5	10.000	75.100
1.0	10.000	75.100
1.5	10.000	75.100
2.0	10.000	75.100
2.5	8.597	64.563
3.0	6.303	47.336
3.5	5.016	37.670
4.0	4.217	31.670
4.5	3.620	27.186
5.0	3.103	23.304
5.5	2.660	19.977
6.0	2.282	17.138
6.5	1.943	14.592
7.0	1.697	12.744
7.5	1.485	11.152
8.0	1.340	10.063
8.5	1.200	9.012
9.0	1.102	8.276
9.5	1.015	7.623
10.0	914	6.864
10.5	822	6.173
11.0	755	5.670
11.5	697	5.234
12.0	644	4.836
12.5	596	4.476
13.0	549	4.123
13.5	510	3.830
14.0	476	3.575

The effective 'K' value is 0.70. 'K' equals effective column length factor. See introduction to column tables showing notation factors

10 X 5 X 3/8 I-BEAM

$A = 7.22 \text{ in}^2$

$r = 1.04 \text{ in}$

$b/t = 13.3$

TRUE LENGTH (ft)	F_a (psi)	P_a (lbs)
0.5	8.747	63.153
1.0	8.747	63.153
1.5	8.747	63.153
2.0	8.747	63.153
2.5	8.747	63.153
3.0	8.747	63.153
3.5	6.814	49.197
4.0	5.520	39.854
4.5	4.711	34.013
5.0	4.097	29.580
5.5	3.620	26.136
6.0	3.186	23.003
6.5	2.833	20.454
7.0	2.470	17.833
7.5	2.188	15.797
8.0	1.918	13.848
8.5	1.714	12.375
9.0	1.540	11.119
9.5	1.404	10.137
10.0	1.288	9.299
10.5	1.179	8.512
11.0	1.103	7.964
11.5	1.033	7.458
12.0	954	6.888
12.5	869	6.274
13.0	800	5.776
13.5	751	5.422
14.0	704	5.083
14.5	658	4.751
15.0	619	4.469
15.5	581	4.195
16.0	543	3.920
16.5	511	3.689
17.0	482	3.480

The effective 'K' value is 0.70. 'K' equals effective column length factor. See introduction to column tables showing notation factors

10 X 5 X 1/2 I-BEAM

$A = 9.51 \text{ in}^2$

$r = 1.05 \text{ in}$

$b/t = 10$

TRUE LENGTH (ft)	F_a (psi)	P_a (lbs)
0.5	10.000	95.100
1.0	10.000	95.100
1.5	10.000	95.100
2.0	10.000	95.100
2.5	10.000	95.100
3.0	9.163	87.140
3.5	6.917	65.781
4.0	5.605	53.304
4.5	4.765	45.315
5.0	4.157	39.533
5.5	3.666	34.864
6.0	3.227	30.689
6.5	2.880	27.389
7.0	2.517	23.937
7.5	2.232	21.226
8.0	1.963	18.668
8.5	1.739	16.538
9.0	1.564	14.874
9.5	1.429	13.590
10.0	1.311	12.468
10.5	1.200	11.412
11.0	1.120	10.651
11.5	1.049	9.976
12.0	975	9.272
12.5	889	8.484
13.0	818	7.779
13.5	764	7.266
14.0	717	6.819
14.5	669	6.362
15.0	630	5.991
15.5	592	5.630
16.0	554	5.269
16.5	520	4.945
17.0	491	4.669
17.5	467	4.441

The effective 'K' value is 0.70. 'K' equals effective column length factor. See introduction to column tables showing notation factors

12 X 6 X 1/2 I-BEAM

$A = 11.51 \text{ in}^2$

$r = 1.26 \text{ in}$

$b/t = 12$

TRUE LENGTH (ft)	F_a (psi)	P_a (lbs)
0.5	10.000	115.100
1.0	10.000	115.100
1.5	10.000	115.100
2.0	10.000	115.100
2.5	10.000	115.100
3.0	10.000	115.100
3.5	9.800	112.798
4.0	7.502	86.348
4.5	6.182	71.155
5.0	5.310	61.118
5.5	4.653	53.556
6.0	4.157	47.847
6.5	3.741	43.059
7.0	3.364	38.720
7.5	3.063	35.255
8.0	2.753	31.687
8.5	2.458	28.292
9.0	2.232	25.690
9.5	2.008	23.112
10.0	1.793	20.637
10.5	1.667	19.187
11.0	1.513	17.415
11.5	1.411	16.241
12.0	1.311	15.090
12.5	1.217	14.008
13.0	1.144	13.167
13.5	1.084	12.477
14.0	1.025	11.798
14.5	960	11.050
15.0	888	10.221
15.5	828	9.530
16.0	780	8.978
16.5	741	8.529
17.0	701	8.069
17.5	662	7.620
18.0	630	7.251
18.5	598	6.883
19.0	567	6.529
19.5	535	6.158
20.0	510	5.870

The effective 'K' value is 0.70. 'K' equals effective column length factor. See introduction to column tables showing notation factors

3 X 3 X 1/4 WIDE-FLANGE BEAM

$$A = 2.13 \text{ in}^2$$

$$r = 0.73 \text{ in}$$

$$b/t = 12$$

TRUE LENGTH (ft)	F_a (psi)	P_a (lbs)
0.5	10.000	21.300
1.0	10.000	21.300
1.5	10.000	21.300
2.0	10.000	21.300
2.5	7.271	15.487
3.0	5.915	12.599
3.5	5.046	10.748
4.0	4.318	9.197
4.5	3.667	7.811
5.0	3.105	6.614
5.5	2.647	5.638
6.0	2.208	4.703
6.5	1.907	4.062
7.0	1.597	3.402
7.5	1.412	3.008
8.0	1.274	3.714
8.5	1.145	2.439
9.0	1.048	2.232
9.5	965	2.055
10.0	883	1.881
10.5	803	1.710
11.0	719	1.531
11.5	633	1.348
12.0	547	1.165

The effective 'K' value is 0.70. 'K' equals effective column length factor. See introduction to column tables showing notation factors

4 X 4 X 1/4 WIDE-FLANGE BEAM

$A = 2.89 \text{ in}^2$

$r = 0.96 \text{ in}$

$b/t = 16$

TRUE LENGTH (ft)	F_a (psi)	P_a (lbs)
0.5	7,208	20,831
1.0	7,208	20,831
1.5	7,208	20,831
2.0	7,208	20,831
2.5	7,208	20,831
3.0	7,208	20,831
3.5	6,697	19,354
4.0	5,838	16,872
4.5	5,155	14,898
5.0	4,621	13,355
5.5	4,050	11,705
6.0	3,583	10,355
6.5	3,163	9,141
7.0	2,792	8,069
7.5	2,452	7,115
8.0	2,150	6,214
8.5	1,923	5,557
9.0	1,683	4,864
9.5	1,503	4,344
10.0	1,383	3,997
10.5	1,278	3,693
11.0	1,174	3,393
11.5	1,095	3,165
12.0	1,027	2,968
12.5	964	2,786
13.0	902	2,607
13.5	843	2,436
14.0	777	2,246
14.5	714	2,063
15.0	652	1,884
15.5	582	1,682
16.0	520	1,503

The effective 'K' value is 0.70. 'K' equals effective column length factor. See introduction to column tables showing notation factors

6 X 6 X 1/4 WIDE-FLANGE BEAM

A = 4.39 in²

r = 1.43 in

b/t = 24

TRUE LENGTH (ft)	F _a (psi)	P _a (lbs)
0.5	4.167	18.293
1.0	4.167	18.293
1.5	4.167	18.293
2.0	4.167	18.293
2.5	4.167	18.293
3.0	4.167	18.293
3.5	4.167	18.293
4.0	4.167	18.293
4.5	4.167	18.293
5.0	4.167	18.293
5.5	4.167	18.293
6.0	4.167	18.293
6.5	4.167	18.293
7.0	3.997	17.547
7.5	3.666	16.094
8.0	3.334	14.636
8.5	3.068	13.469
9.0	2.800	12.292
9.5	2.534	11.124
10.0	2.322	10.194
10.5	2.097	9.206
11.0	1.917	8.416
11.5	1.754	7.700
12.0	1.644	7.217
12.5	1.510	6.629
13.0	1.419	6.229
13.5	1.332	5.847
14.0	1.244	5.461
14.5	1.171	5.141
15.0	1.118	4.908
15.5	1.066	4.680
16.0	1.013	4.447
16.5	954	4.188
17.0	891	3.911
17.5	834	3.661
18.0	792	3.477
18.5	756	3.319
19.0	722	3.170
19.5	687	3.016
20.0	655	2.875

The effective 'K' value is 0.70. 'K' equals effective column length factor. See introduction to column tables showing notation factors

6 X 6 X 3/8 WIDE-FLANGE BEAM

A = 6.48 in²

r = 1.44 in

b/t = 16

TRUE LENGTH (ft)	F _a (psi)	P _a (lbs)
0.5	6.233	40.390
1.0	6.233	40.390
1.5	6.233	40.390
2.0	6.233	40.390
2.5	6.233	40.390
3.0	6.233	40.390
3.5	6.233	40.390
4.0	6.233	40.390
4.5	6.233	40.390
5.0	6.233	40.390
5.5	5.586	36.197
6.0	4.917	31.862
6.5	4.447	28.817
7.0	4.037	26.160
7.5	3.695	23.944
8.0	3.365	21.805
8.5	3.093	20.043
9.0	2.833	18.358
9.5	2.563	16.608
10.0	2.345	15.196
10.5	2.123	13.757
11.0	1.948	12.623
11.5	1.774	11.496
12.0	1.667	10.802
12.5	1.528	9.901
13.0	1.436	9.305
13.5	1.347	8.729
14.0	1.260	8.165
14.5	1.206	7.815
15.0	1.129	7.316
15.5	1.076	6.972
16.0	1.025	6.642
16.5	969	6.279
17.0	906	5.871
17.5	845	5.476
18.0	800	5.184
18.5	765	4.957
19.0	731	4.737
19.5	696	4.510
20.0	662	4.290

The effective 'K' value is 0.70. 'K' equals effective column length factor. See introduction to column tables showing notation factors

8 X 8 X 3/8 WIDE-FLANGE BEAM

A = 8.73 in²

r = 1.92 in

b/t = 21.3

TRUE LENGTH (ft)	F _a (psi)	P _a (lbs)
0.5	4.483	39.137
1.0	4.483	39.137
1.5	4.483	39.137
2.0	4.483	39.137
2.5	4.483	39.137
3.0	4.483	39.137
3.5	4.483	39.137
4.0	4.483	39.137
4.5	4.483	39.137
5.0	4.483	39.137
5.5	4.483	39.137
6.0	4.483	39.137
6.5	4.483	39.137
7.0	4.483	39.137
7.5	4.483	39.137
8.0	4.483	39.137
8.5	4.483	39.137
9.0	4.237	36.989
9.5	3.927	34.283
10.0	3.695	32.257
10.5	3.450	30.119
11.0	3.213	28.049
11.5	3.038	26.522
12.0	2.833	24.732
12.5	2.627	22.934
13.0	2.442	21.319
13.5	2.297	20.053
14.0	2.129	18.586
14.5	2.003	17.486
15.0	1.843	16.089
15.5	1.744	15.225
16.0	1.667	14.553
16.5	1.563	13.645
17.0	1.477	12.894
17.5	1.413	12.335
18.0	1.348	11.768
18.5	1.283	11.201
19.0	1.220	10.651
19.5	1.169	10.205
20.0	1.129	9.856

The effective 'K' value is 0.70. 'K' equals effective column length factor. See introduction to column tables showing notation factors

8 X 8 X 1/2 WIDE-FLANGE BEAM

$A = 11.51 \text{ in}^2$

$r = 1.93 \text{ in}$

$b/t = 16$

TRUE LENGTH (ft)	F_a (psi)	P_a (lbs)
0.5	6.233	71.742
1.0	6.233	71.742
1.5	6.233	71.742
2.0	6.233	71.742
2.5	6.233	71.742
3.0	6.233	71.742
3.5	6.233	71.742
4.0	6.233	71.742
4.5	6.233	71.742
5.0	6.233	71.742
5.5	6.233	71.742
6.0	6.233	71.742
6.5	6.233	71.742
7.0	6.037	69.486
7.5	5.460	62.845
8.0	4.966	57.159
8.5	4.606	53.015
9.0	4.267	49.133
9.5	3.957	45.545
10.0	3.718	42.794
10.5	3.475	39.997
11.0	3.240	37.292
11.5	3.058	35.198
12.0	2.860	32.919
12.5	2.653	30.536
13.0	2.470	28.430
13.5	2.321	26.715
14.0	2.158	24.839
14.5	2.023	23.285
15.0	1.868	21.501
15.5	1.757	20.223
16.0	1.679	19.325
16.5	1.580	18.186
17.0	1.491	17.161
17.5	1.425	16.402
18.0	1.360	15.654
18.5	1.296	14.917
19.0	1.231	14.169
19.5	1.179	13.570
20.0	1.137	13.087

The effective 'K' value is 0.70. 'K' equals effective column length factor. See introduction to column tables showing notation factors

10 X 10 X 3/8 WIDE-FLANGE BEAM

$A = 11.06 \text{ in}^2$

$r = 2.38 \text{ in}$

$b/t = 26.7$

TRUE LENGTH (ft)	F_a (psi)	P_a (lbs)
0.5	2.732	30.216
1.0	2.732	30.216
1.5	2.732	30.216
2.0	2.732	30.216
2.5	2.732	30.216
3.0	2.732	30.216
3.5	2.732	30.216
4.0	2.732	30.216
4.5	2.732	30.216
5.0	2.732	30.216
5.5	2.732	30.216
6.0	2.732	30.216
6.5	2.732	30.216
7.0	2.732	30.216
7.5	2.732	30.216
8.0	2.732	30.216
8.5	2.732	30.216
9.0	2.732	30.216
9.5	2.732	30.216
10.0	2.732	30.216
10.5	2.732	30.216
11.0	2.732	30.216
11.5	2.732	30.216
12.0	2.732	30.216
12.5	2.732	30.216
13.0	2.732	30.216
13.5	2.732	30.216
14.0	2.732	30.216
14.5	2.732	30.216
15.0	2.732	30.216
15.5	2.621	28.988
16.0	2.476	27.385
16.5	2.349	25.980
17.0	2.232	24.686
17.5	2.093	23.149
18.0	1.993	22.043
18.5	1.868	20.660
19.0	1.773	19.609
19.5	1.709	18.902
20.0	1.640	18.138

The effective 'K' value is 0.70. 'K' equals effective column length factor. See introduction to column tables showing notation factors

10 X 10 X 1/2 WIDE-FLANGE BEAM

$A = 14.51 \text{ in}^2$

$r = 2.4 \text{ in}$

$b/t = 20$

TRUE LENGTH (ft)	F_a (psi)	P_a (lbs)
0.5	4.920	71.389
1.0	4.920	71.389
1.5	4.920	71.389
2.0	4.920	71.389
2.5	4.920	71.389
3.0	4.920	71.389
3.5	4.920	71.389
4.0	4.920	71.389
4.5	4.920	71.389
5.0	4.920	71.389
5.5	4.920	71.389
6.0	4.920	71.389
6.5	4.920	71.389
7.0	4.920	71.389
7.5	4.920	71.389
8.0	4.920	71.389
8.5	4.920	71.389
9.0	4.920	71.389
9.5	4.920	71.389
10.0	4.917	71.346
10.5	4.641	67.341
11.0	4.367	63.365
11.5	4.117	59.738
12.0	3.867	56.110
12.5	3.695	53.614
13.0	3.500	50.785
13.5	3.304	47.941
14.0	3.133	45.460
14.5	2.999	43.515
15.0	2.833	41.107
15.5	2.966	43.037
16.0	2.517	36.522
16.5	2.379	34.519
17.0	2.267	32.894
17.5	2.129	30.892
18.0	2.033	29.499
18.5	1.908	27.685
19.0	1.800	26.118
19.5	1.729	25.088
20.0	1.667	24.188

The effective 'K' value is 0.70. 'K' equals effective column length factor. See introduction to column tables showing notation factors

12 X 12 X 1/2 WIDE-FLANGE BEAM

A = 17.51 in²
r = 2.87 in
b/t = 24

TRUE LENGTH (ft)	F _a (psi)	P _a (lbs)
0.5	3.608	63.176
1.0	3.608	63.176
1.5	3.608	63.176
2.0	3.608	63.176
2.5	3.608	63.176
3.0	3.608	63.176
3.5	3.608	63.176
4.0	3.608	63.176
4.5	3.608	63.176
5.0	3.608	63.176
5.5	3.608	63.176
6.0	3.608	63.176
6.5	3.608	63.176
7.0	3.608	63.176
7.5	3.608	63.176
8.0	3.608	63.176
8.5	3.608	63.176
9.0	3.608	63.176
9.5	3.608	63.176
10.0	3.608	63.176
10.5	3.608	63.176
11.0	3.608	63.176
11.5	3.608	63.176
12.0	3.608	63.176
12.5	3.608	63.176
13.0	3.608	63.176
13.5	3.608	63.176
14.0	3.608	63.176
14.5	3.608	63.176
15.0	3.608	63.176
15.5	3.516	61.565
16.0	3.349	58.641
16.5	3.200	56.032
17.0	3.078	53.896
17.5	2.954	51.725
18.0	2.813	49.256
18.5	2.673	46.804
19.0	2.552	44.686
19.5	2.429	42.532
20.0	2.333	40.851

The effective 'K' value is 0.70. 'K' equals effective column length factor. See introduction to column tables showing notation factors

2 X 2 X 1/4 SQUARE TUBE

$A = 1.74 \text{ in}^2$

$r = 0.73 \text{ in}$

$b/t = 8$

TRUE LENGTH (ft)	F_a (psi)	P_a (lbs)
0.5	10.000	17.400
1.0	10.000	17.400
1.5	10.000	17.400
2.0	9.850	17.139
2.5	8.650	15.051
3.0	7.450	12.963
3.5	6.491	11.294
4.0	5.684	9.890
4.5	5.000	8.700
5.0	4.253	7.400
5.5	3.726	6.483
6.0	3.188	5.547
6.5	2.786	4.848
7.0	2.454	4.270
7.5	2.111	3.673
8.0	1.895	3.297
8.5	1.722	2.996
9.0	1.585	2.758
9.5	1.448	2.520
10.0	1.370	2.384
10.5	1.276	2.220
11.0	1.189	2.069
11.5	1.079	1.877
12.0	957	1.665

The effective 'K' value is 0.70. 'K' equals effective column length factor. See introduction to column tables showing notation factors

2-1/2 X 2-1/2 X 1/4 SQUARE TUBE

$A = 2.24 \text{ in}^2$

$r = 0.92 \text{ in}$

$b/t = 10$

TRUE LENGTH (ft)	F_a (psi)	P_a (lbs)
0.5	10.000	22.400
1.0	10.000	22.400
1.5	10.000	22.400
2.0	10.000	22.400
2.5	9.900	22.176
3.0	8.816	19.748
3.5	7.842	17.566
4.0	7.078	15.855
4.5	6.351	14.226
5.0	5.733	12.842
5.5	5.192	11.630
6.0	4.675	10.472
6.5	4.146	9.287
7.0	3.673	8.228
7.5	3.246	7.271
8.0	2.904	6.505
8.5	2.629	5.889
9.0	2.358	5.282
9.5	2.087	4.675
10.0	1.923	4.308
10.5	1.825	4.088
11.0	1.641	3.676
11.5	1.533	3.434
12.0	1.445	3.237
12.5	1.387	3.107
13.0	1.320	2.957
13.5	1.239	2.775
14.0	1.163	2.605
14.5	1.077	2.412
15.0	977	2.188

The effective 'K' value is 0.70. 'K' equals effective column length factor. See introduction to column tables showing notation factors

3 X 3 X 1/4 SQUARE TUBE

$A = 2.74 \text{ in}^2$

$r = 1.13 \text{ in}$

$b/t = 12$

TRUE LENGTH (ft)	F_a (psi)	P_a (lbs)
0.5	8.880	24.331
1.0	8.880	24.331
1.5	8.880	24.331
2.0	8.880	24.331
2.5	8.880	24.331
3.0	8.880	24.331
3.5	8.880	24.331
4.0	8.273	22.668
4.5	7.573	20.750
5.0	6.976	19.114
5.5	6.386	17.498
6.0	5.857	16.048
6.5	5.416	14.840
7.0	4.977	13.637
7.5	4.566	12.511
8.0	4.133	11.324
8.5	3.732	10.226
9.0	3.397	9.308
9.5	3.046	8.346
10.0	2.821	7.730
10.5	2.604	7.135
11.0	2.383	6.529
11.5	2.163	5.927
12.0	2.013	5.516
12.5	1.865	5.110
13.0	1.748	4.790
13.5	1.643	4.502
14.0	1.565	4.288
14.5	1.467	4.020
15.0	1.428	3.913
15.5	1.367	3.746
16.0	1.308	3.584
16.5	1.248	3.420
17.0	1.193	3.269
17.5	1.121	3.072
18.0	1.052	2.882

The effective 'K' value is 0.70. 'K' equals effective column length factor. See introduction to column tables showing

4 X 4 X 1/4 SQUARE TUBE

A = 3.74 in²

r = 1.53 in

b/t = 16

TRUE LENGTH (ft)	F _a (psi)	P _a (lbs)
0.5	6.595	24.665
1.0	6.595	24.665
1.5	6.595	24.665
2.0	6.595	24.665
2.5	6.595	24.665
3.0	6.595	24.665
3.5	6.595	24.665
4.0	6.595	24.665
4.5	6.595	24.665
5.0	6.595	24.665
5.5	6.595	24.665
6.0	6.595	24.665
6.5	6.595	24.665
7.0	6.595	24.665
7.5	6.349	23.745
8.0	5.941	22.219
8.5	5.608	20.974
9.0	5.283	19.758
9.5	4.962	18.558
10.0	4.666	17.451
10.5	4.306	16.104
11.0	4.025	15.054
11.5	3.738	13.980
12.0	3.493	13.064
12.5	3.233	12.091
13.0	3.000	11.220
13.5	2.836	10.607
14.0	2.672	9.993
14.5	2.511	9.391
15.0	2.350	8.789
15.5	2.225	8.322
16.0	2.052	7.674
16.5	1.948	7.286
17.0	1.850	6.919
17.5	1.767	6.609
18.0	1.687	6.309
18.5	1.631	6.100
19.0	1.558	5.827
19.5	1.484	5.550
20.0	1.441	5.389

The effective 'K' value is 0.70. 'K' equals effective column length factor. See introduction to column tables showing notation factors